

PNI PT9232S
PNI PT9233S
PNI PT9234S
PNI PT9235S
PNI PT9236S

■ Curtain Track



- » Писта за завеси
- » Vorhangschiene
- » Riel para cortina
- » Rail de rideau
- » Fűgőnypálya
- » Binario per tende
- » Gordijnrail
- » Tor kurtynowy
- » Sina draperii



Contents

English	3
Български	9
Deutsch	15
Español	21
Français	27
Magyar	33
Italiano	39
Nederlands	45
Polski	51
Romana	57

Assembly instructions

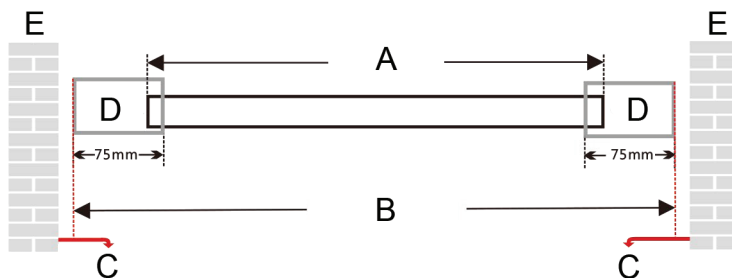

- A. Curtain track
- B. Total length (from wall to wall). It varies depending on the model
- C. At least 5 mm distance from the wall
- D. Transmission box
- E. Wall

Belt

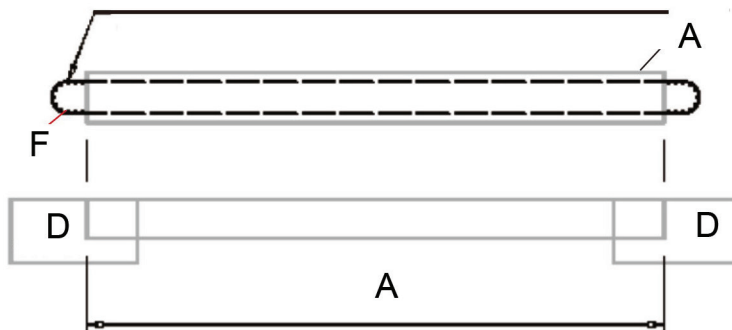

- A. Curtain track
- D. Transmission box
- F. Belt

Join the curtain tracks

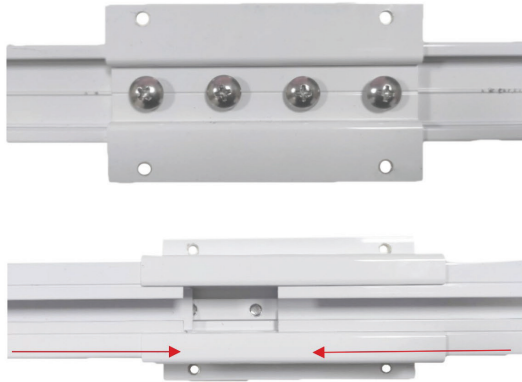

- Loosen the screws, insert the curtain tracks and tighten the screws back

Assembling the belt in the transmission box

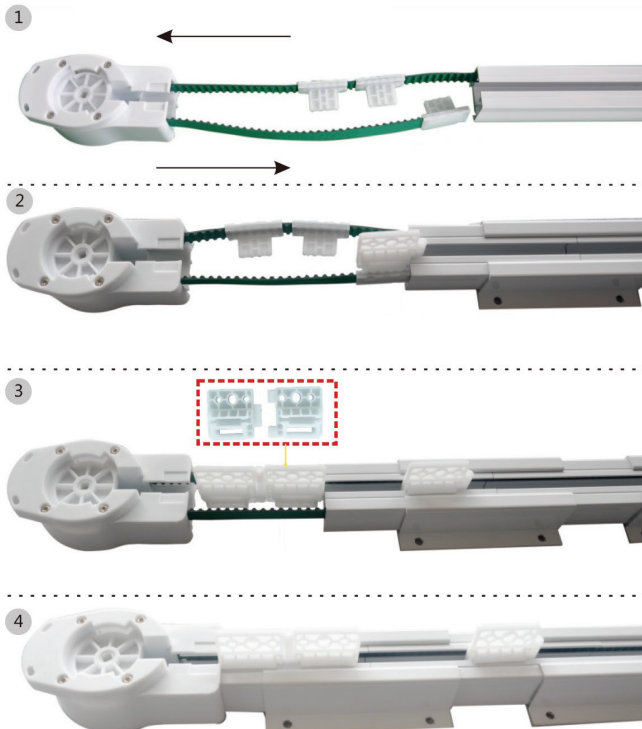

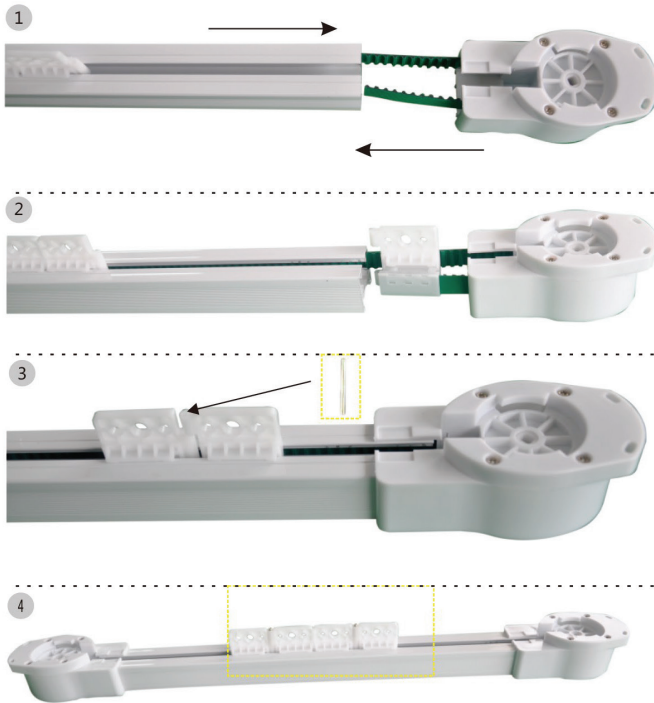

1. Pass the belt through the transmission box.
2. Fix the curtain track in the transmission box.
3. Proceed as in the images above for both ends.

Assembling rings (8 pcs/m) and locking element



Completion of curtain track assembly

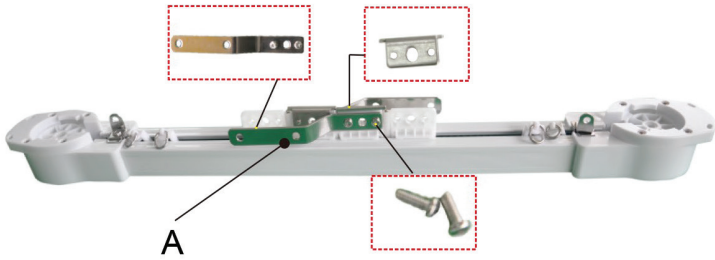

A. Follow the assembly direction as in the image above.

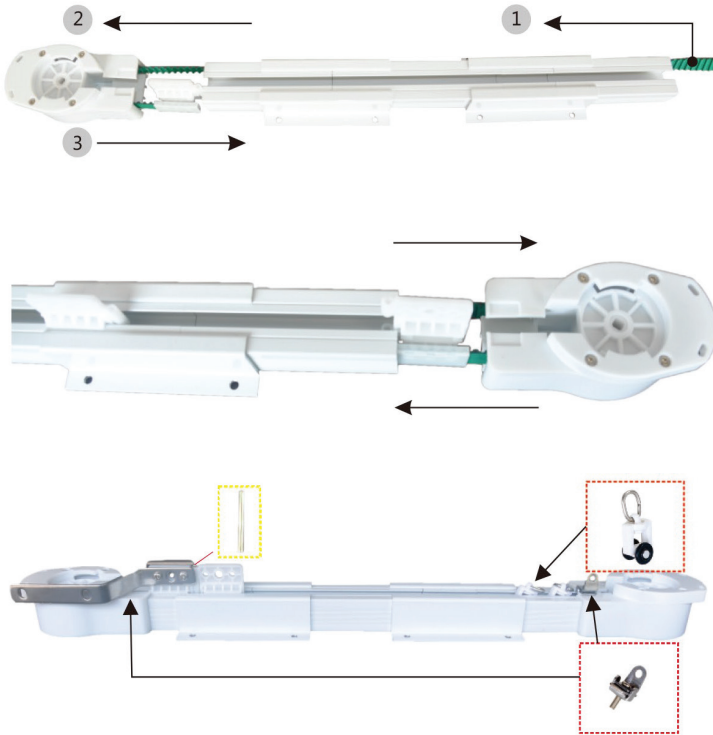

The belt is too long

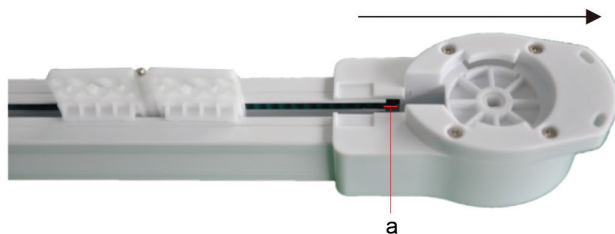

- a. Gap in this place, the belt is too long

The belt is too short



- a. No gap, the belt is too short

Adjust the belt length

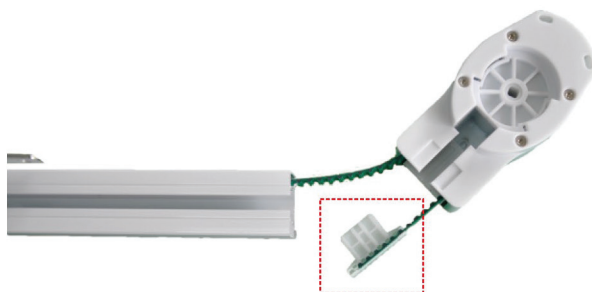

If the belt is too short, pull the buckle out and try again until it runs smoothly

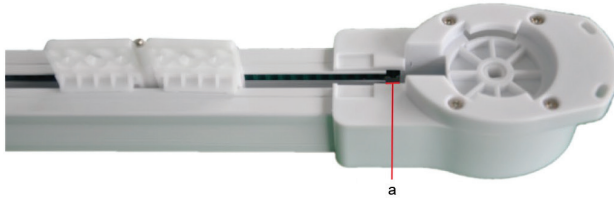

If the belt is too long, cut the belt and try again until it runs smoothly.

Installing the curtain track on the wall

Fix the bracket to the wall with M4x25mm self-tapping screws.

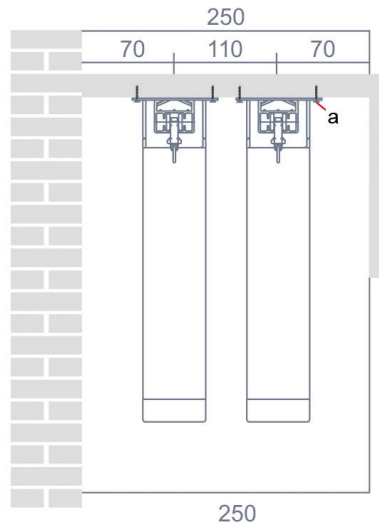
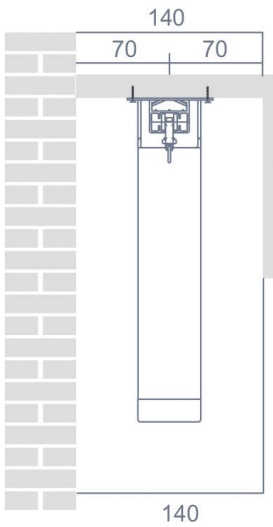
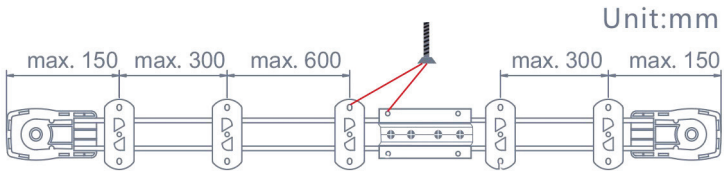

инструкции за сглобяване

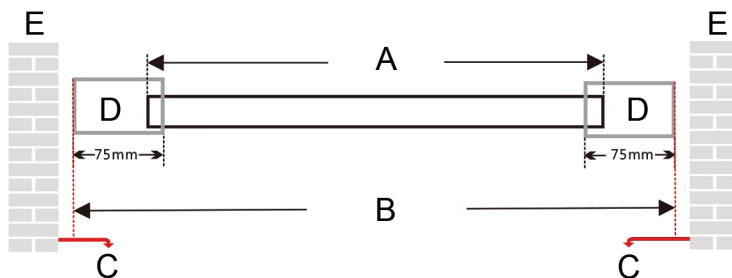

- A. Писта за завеси
- B. Обща дължина (от стена до стена). Тя варира в зависимост от модела
- C. Най-малко 5 mm разстояние от стената
- D. Предавателна кутия
- E. Стена

Колан

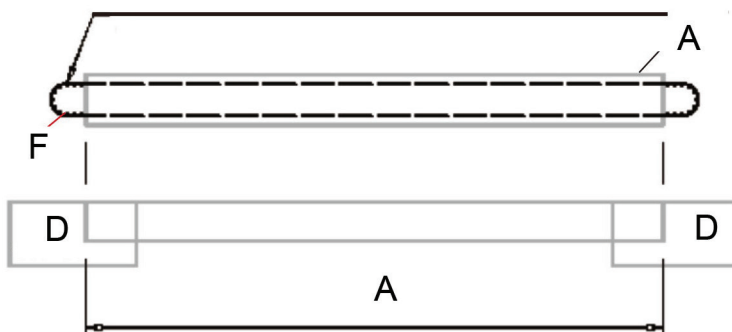

- A. Писта за завеси
- D. Предавателна кутия
- F. Колан

Присъединете се към пистите за завеси

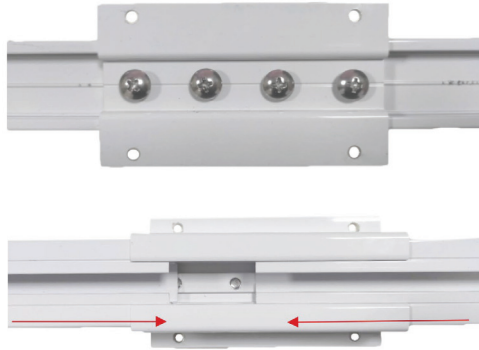

- Разхлабете винтовете, поставете релсите за завеси и затегнете обратно винтовете

Сглобяване на ремъка в трансмисионната кутия

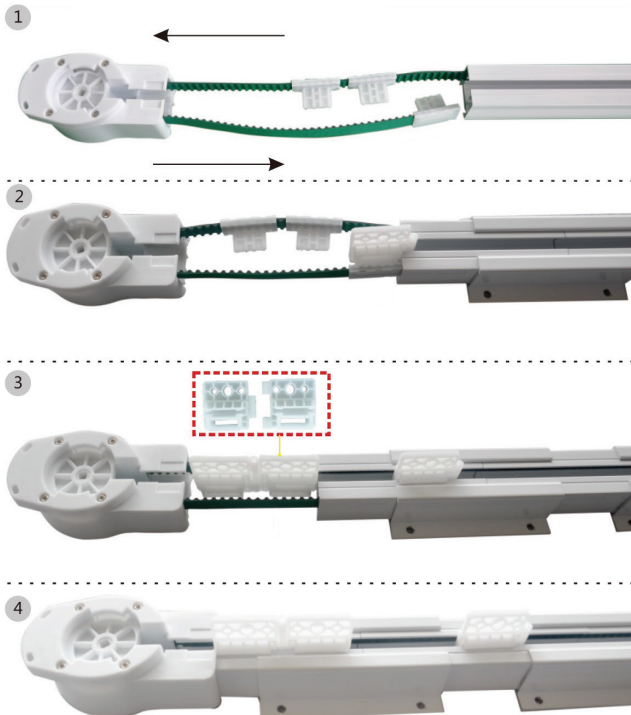

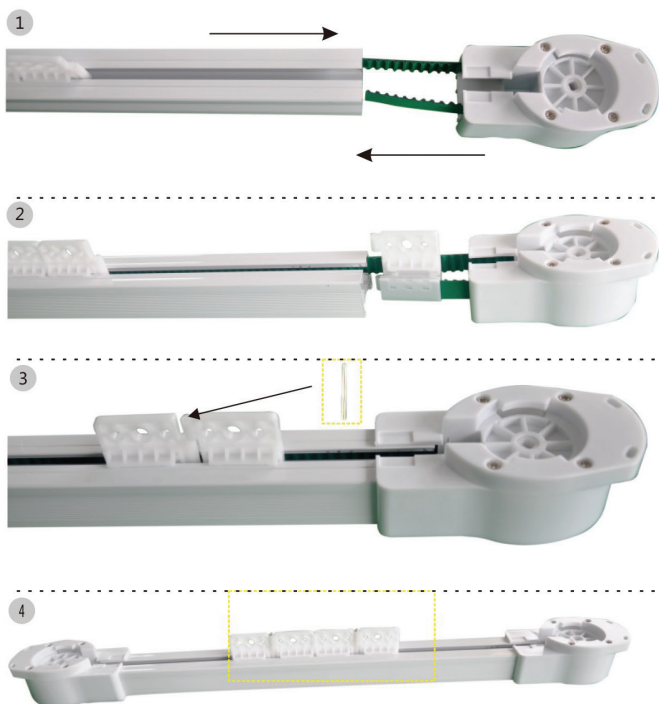

1. Прекарайте ремъка през трансмисионната кутия.
2. Фиксирайте релсата на завесата в трансмисионната кутия.
3. Продължете както на изображенията по-горе за двата края.

Монтажни пръстени (8 бр/м) и заключващ елемент



Завършване на монтажа на корнизи

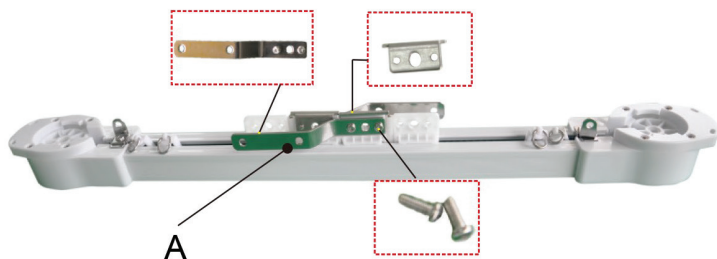

A. Следвайте посоката на сглобяване, както е на изображението по-горе.

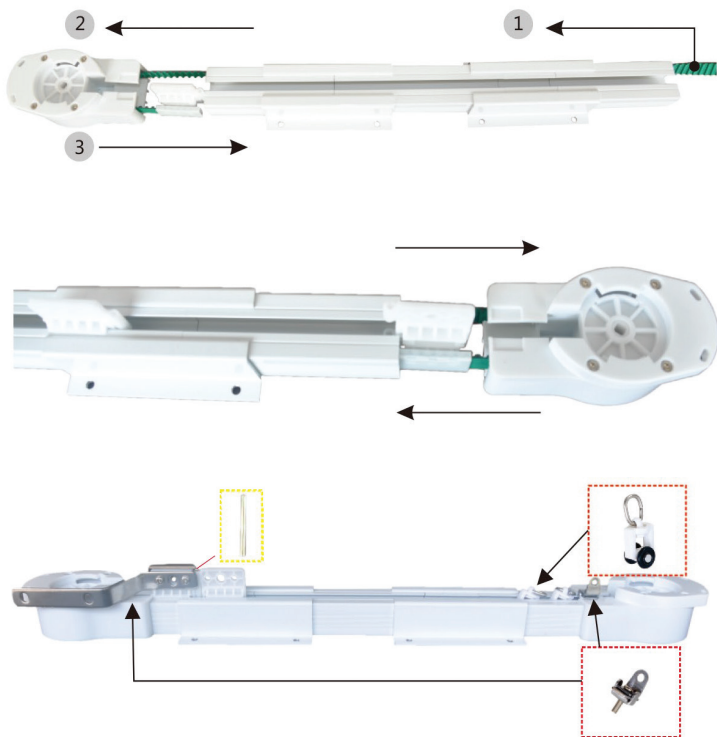

Коланът е твърде дълъг

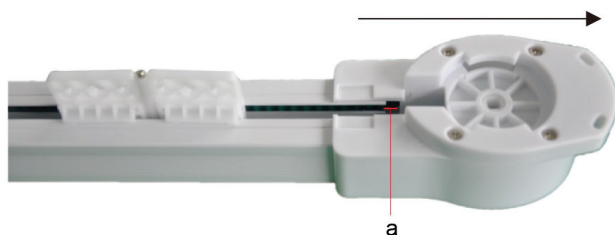

- а. Празнина на това място, коланът е твърде дълъг

Коланът е твърде къс



- а. Няма празнина, коланът е твърде къс

Регулирайте дължината на колана

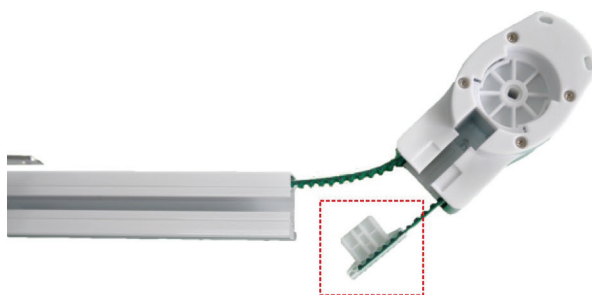

Ако коланът е твърде къс, издърпайте катарамата и опитайте отново, докато работи гладко

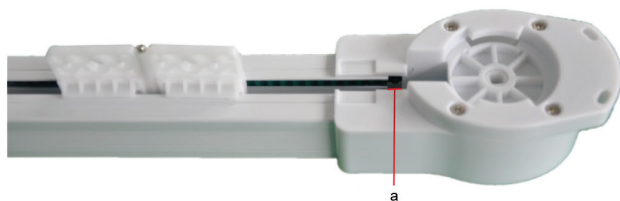

Ако ремъкът е твърде дълъг, отрежете го и опитайте отново, докато работи гладко.

Монтиране на пистата за завеси на стената

Фиксирайте скобата към стената с M4x25mm самонарезни винтове.

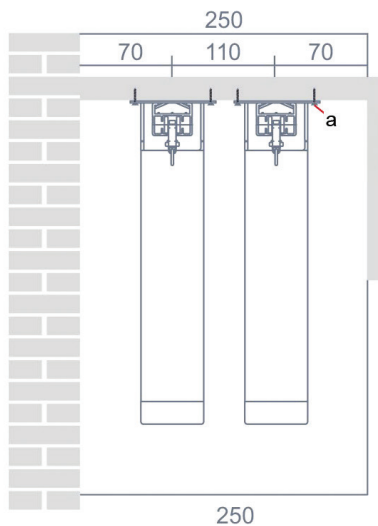
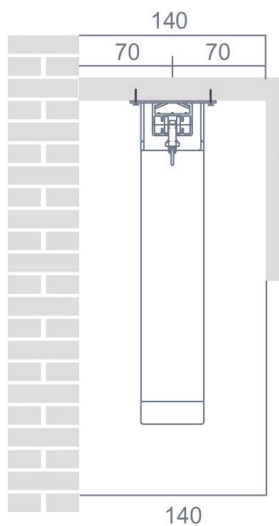
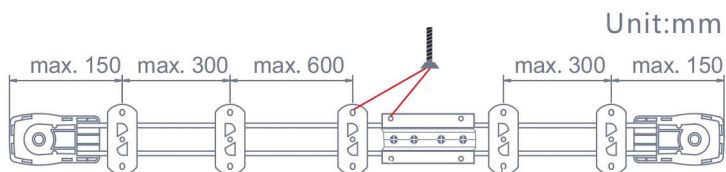

Montageanleitungen

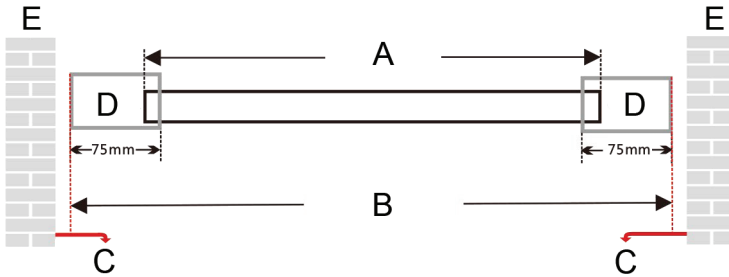

- A. Vorhangschiene
- B. Gesamtlänge (von Wand zu Wand). Sie variiert je nach Modell
- C. Mindestens 5 mm Abstand zur Wand
- D. Übertragungsbox
- E. Wand

Gürtel

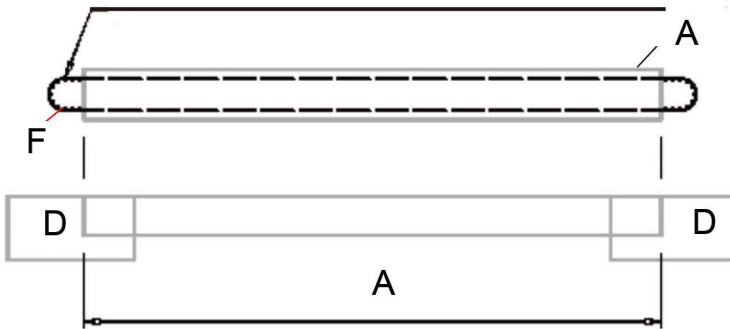

- A. Vorhangschiene
- D. Übertragungsbox
- F. Gürtel

Vorhangschienen verbinden

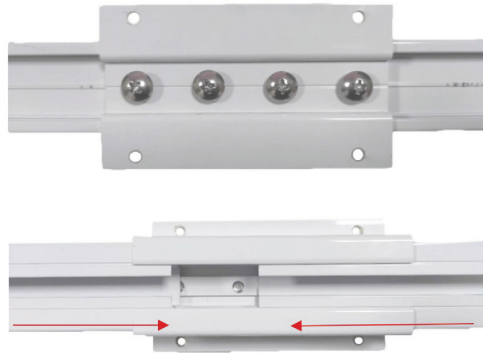

- Die Schrauben lösen, die Vorhangschienen einsetzen und die Schrauben wieder festziehen

Montage des Riemens im Getriebe

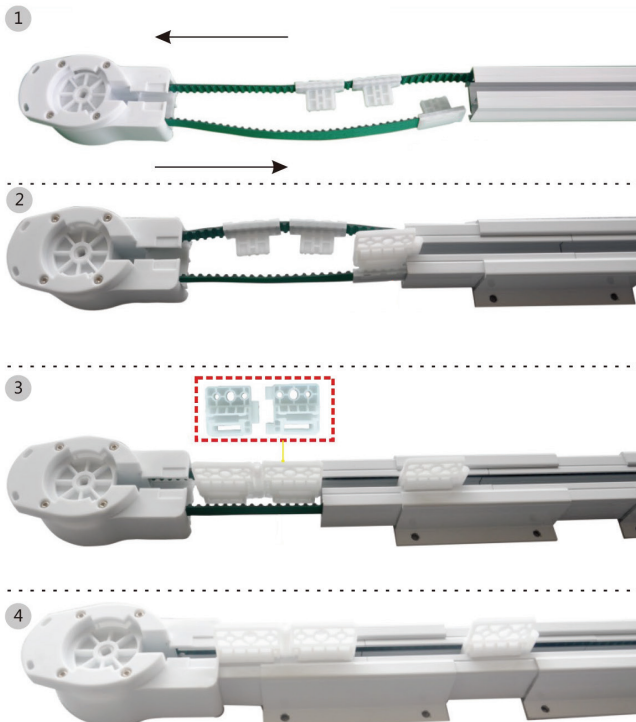

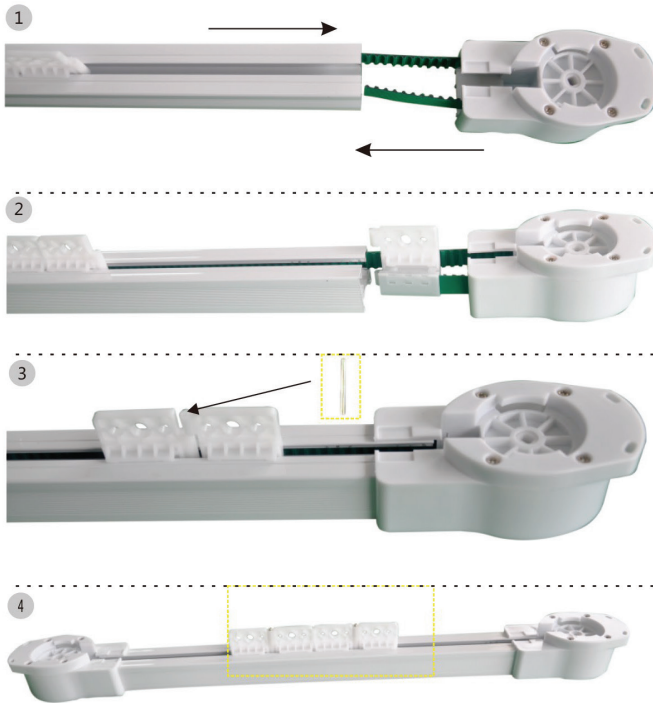

1. Führen Sie den Riemen durch das Übertragungsgehäuse.
2. Befestigen Sie die Vorhangschiene im Übertragungsgehäuse.
3. Gehen Sie für beide Enden wie in den obigen Bildern vor..

Montageringe (8 Stk./m) und Verriegelungselement



Fertigstellung der Vorhangschienenmontage

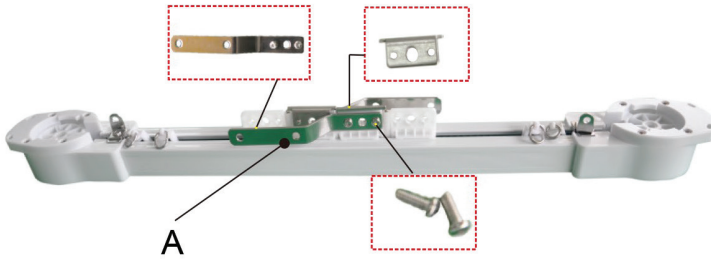

A. Befolgen Sie die Montagerichtung wie im Bild oben.

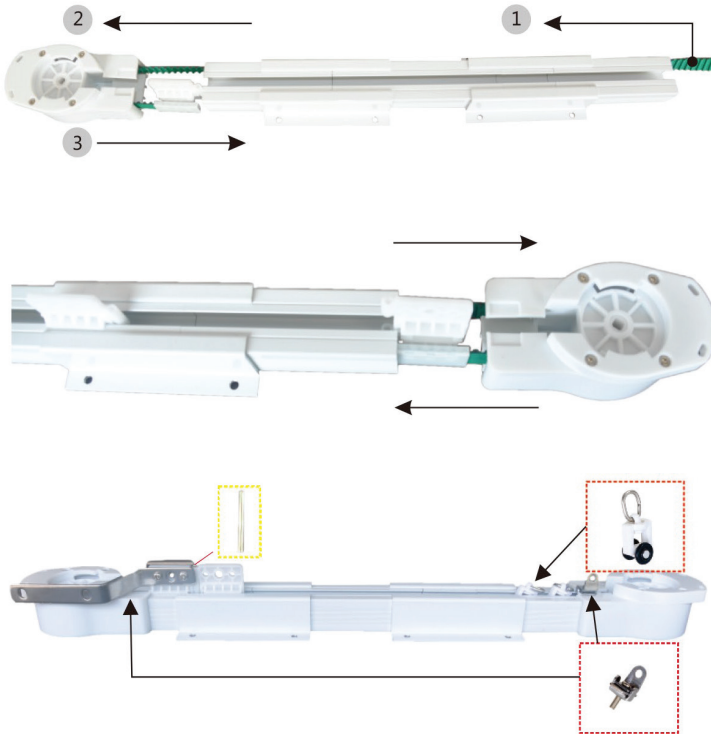

Der Gürtel ist zu lang

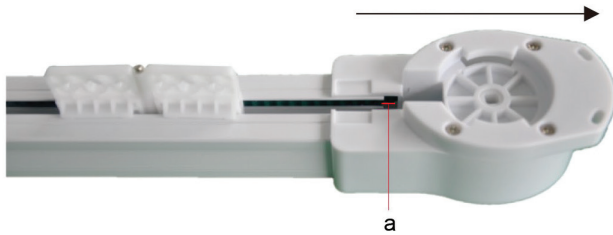

- a. Lücke an dieser Stelle, der Gürtel ist zu lang

Der Gürtel ist zu kurz



- a. Keine Lücke, der Riemen ist zu kurz

Passen Sie die Gürtellänge an

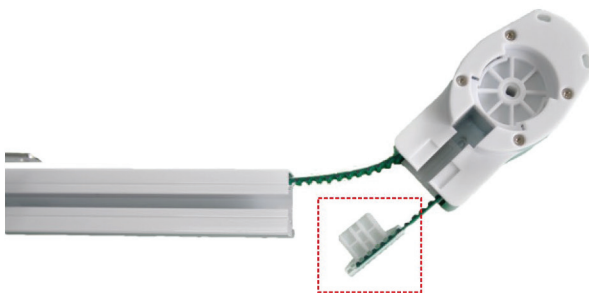

Wenn der Gurt zu kurz ist, ziehe die Schnalle heraus und probiere es erneut, bis er reibungslos läuft

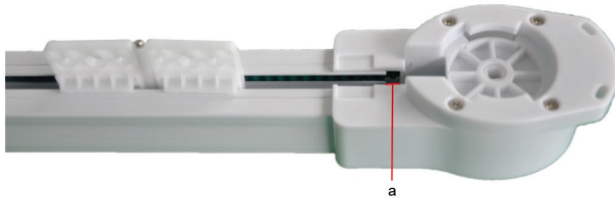

Wenn der Riemen zu lang ist, kürzen Sie ihn und versuchen Sie es erneut, bis er reibungslos läuft..

Montage der Gardinenschiene an der Wand

Befestigen Sie die Halterung mit M4x25mm Blechschrauben an der Wand.

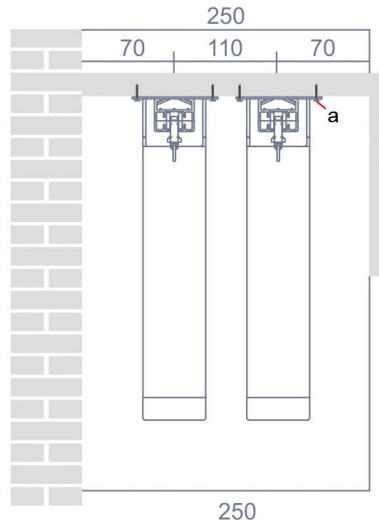
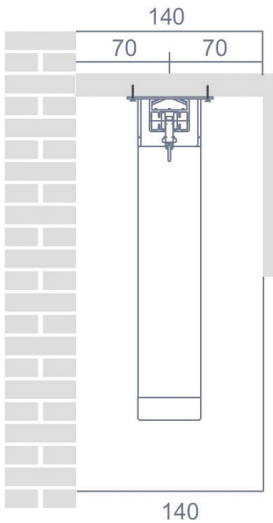
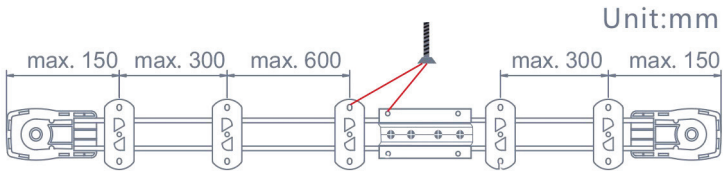

Instrucciones de montaje

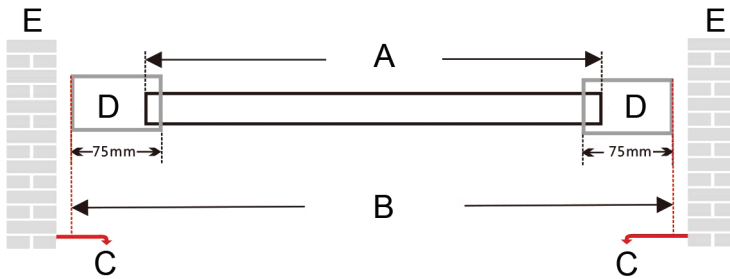

- A. Pista de cortina
- B. Longitud total (de pared a pared). Varía según el modelo.
- C. Al menos 5 mm de distancia de la pared
- D. Caja de transmisión
- E. Muro

Cinturón

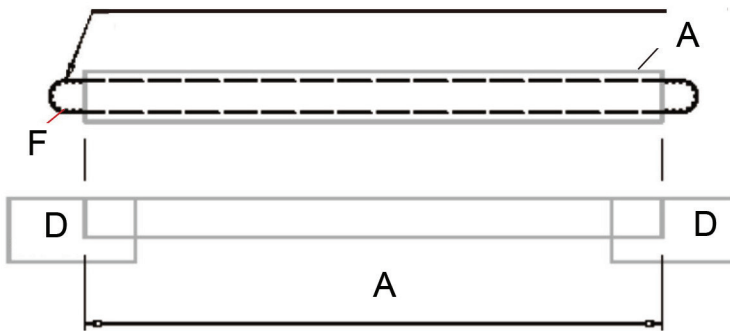

- A. Pista de cortina
- D. Caja de transmisión
- F. Cinturón

Unir rieles de cortina

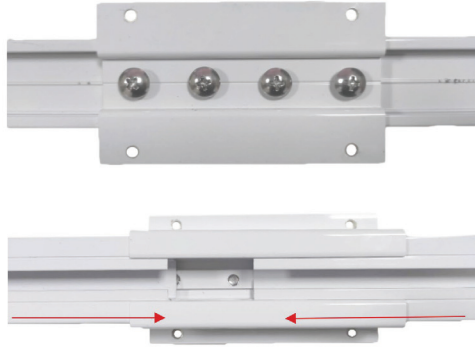

- Afloje los tornillos, inserte los rieles de la cortina y apriete los tornillos nuevamente.

Montaje de la correa en la caja de transmisión.

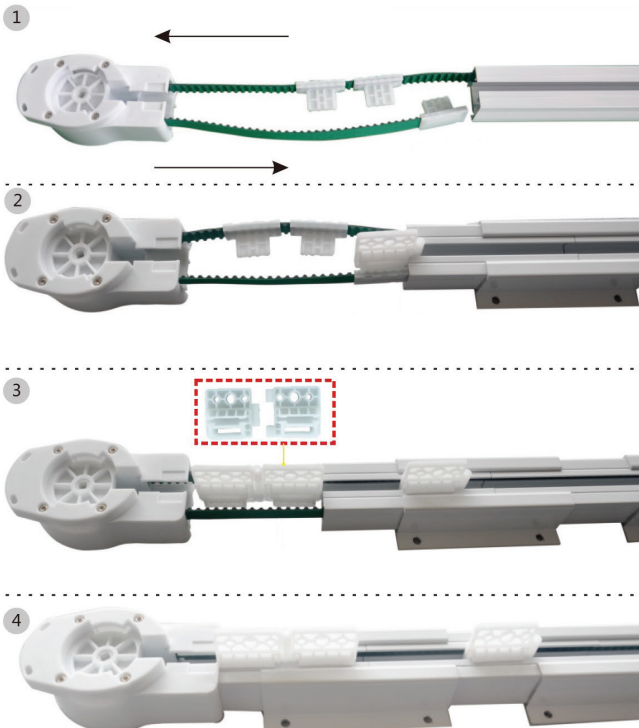

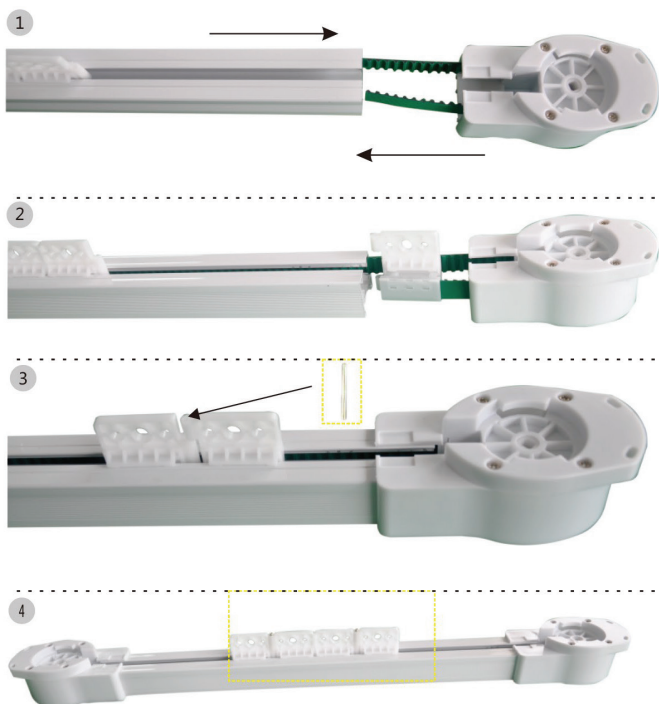

1. Pasar la correa por la caja de transmisión.
2. Fije el riel de la cortina en la caja de transmisión.
3. Proceda como en las imágenes de arriba para ambos extremos.

Anillos de montaje (8 piezas/m) y elemento de bloqueo



Finalización del montaje del riel de la cortina.

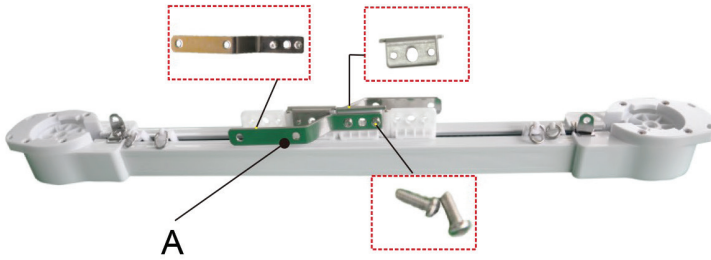

A. Siga la dirección de montaje como en la imagen de arriba..

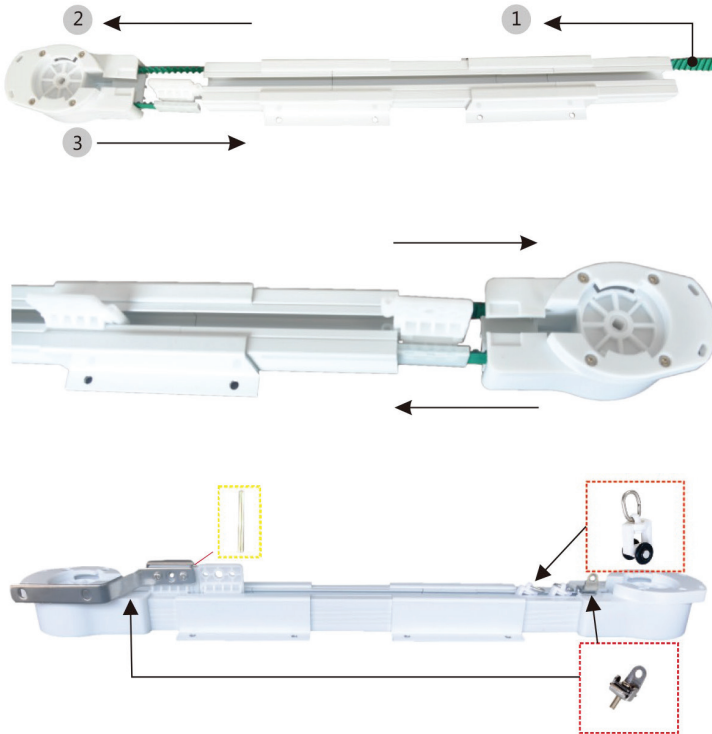

El cinturón es demasiado largo.

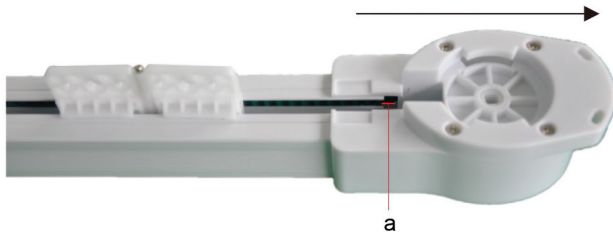

a. Espacio en este lugar, el cinturón es demasiado largo.

El cinturón es demasiado corto.



a. No hay espacio, el cinturón es demasiado corto.

Ajustar la longitud del cinturón

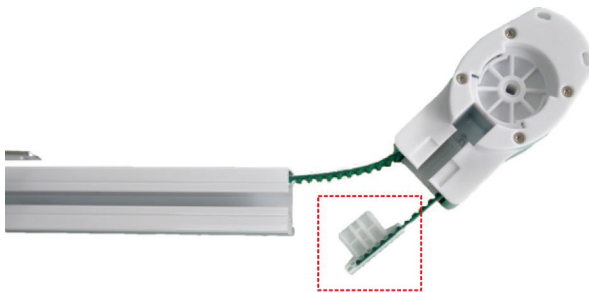

Si el cinturón es demasiado corto, saque la hebilla y vuelva a intentarlo hasta que funcione sin problemas.

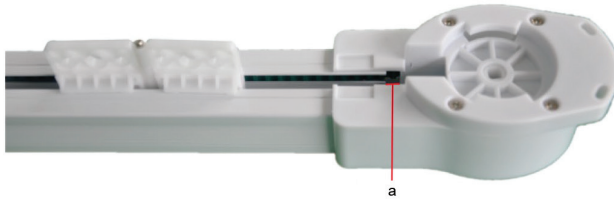

Si el cinturón es demasiado largo, córtelo y vuelva a intentarlo hasta que funcione sin problemas..

Instalación del riel de la cortina en la pared.

Fije el soporte a la pared con tornillos autorroscantes M4x25mm.

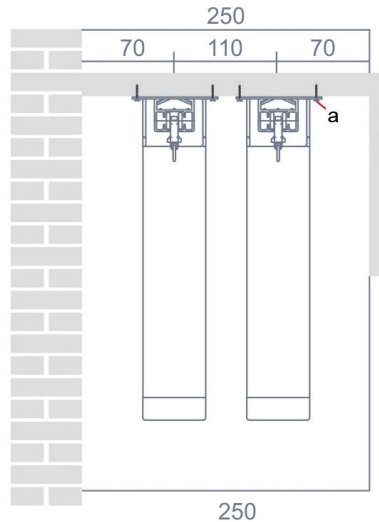
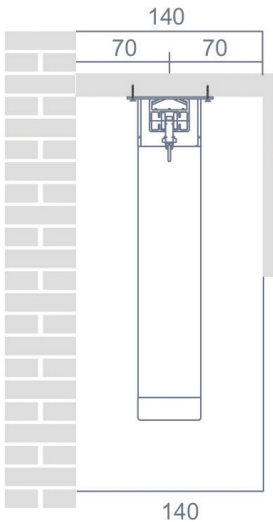
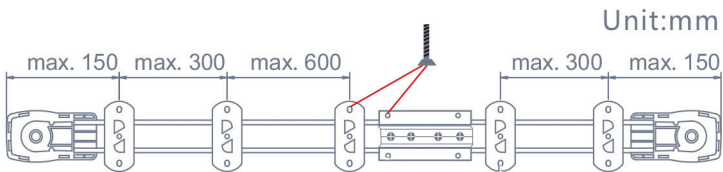

Instructions de montage

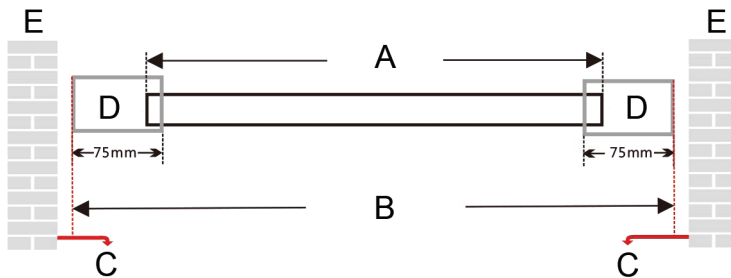

- A. Rail de rideau
- B. Longueur totale (de mur à mur). Cela varie selon le modèle
- C. Distance d'au moins 5 mm du mur
- D. Boîte de transmission
- E. Mur

Ceinture

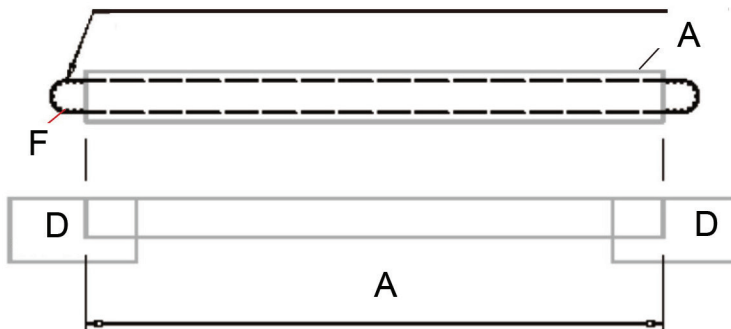

- A. Rail de rideau
- D. Boîte de transmission
- F. Ceinture

Rejoignez les tringles à rideaux

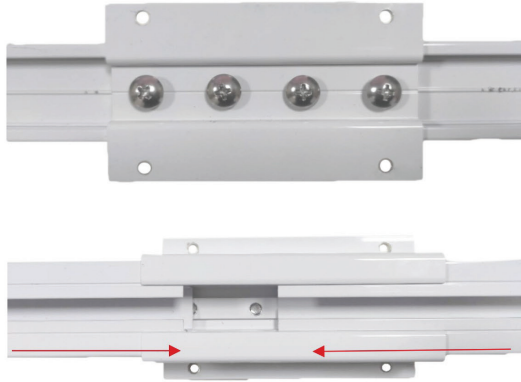

- Desserrez les vis, insérez les tringles à rideaux et resserrez les vis.

Assemblage de la courroie dans la boîte de transmission

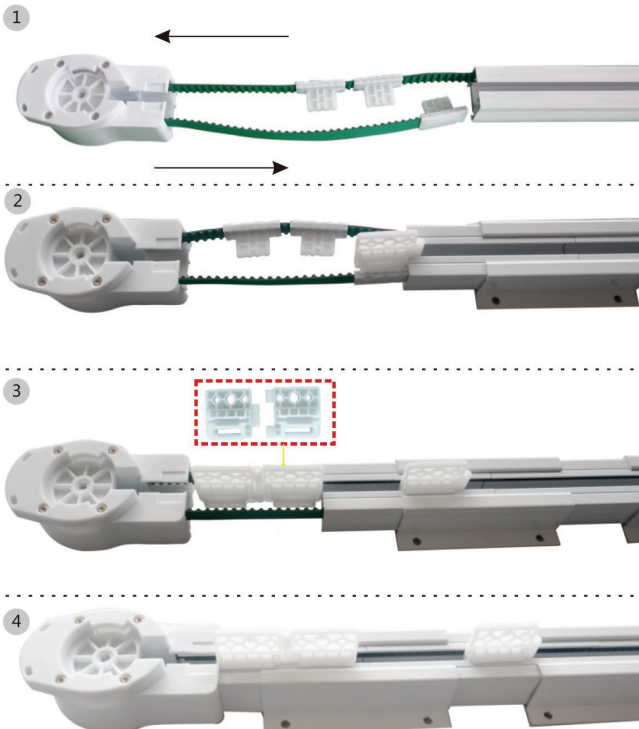

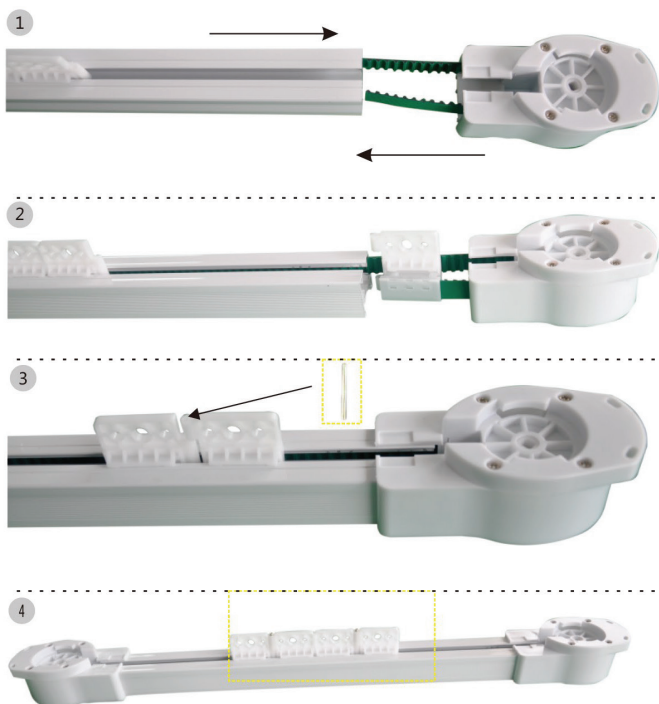

1. Passez la courroie dans la boîte de transmission.
2. Fixez le rail à rideau dans la boîte de transmission.
3. Procédez comme dans les images ci-dessus pour les deux extrémités.

Anneaux d'assemblage (8 pcs/m) et élément de verrouillage



Achèvement de l'assemblage de la tringle à rideaux

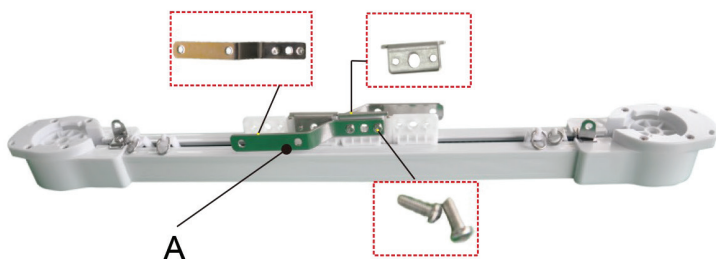

A. Suivez le sens de montage comme dans l'image ci-dessus.

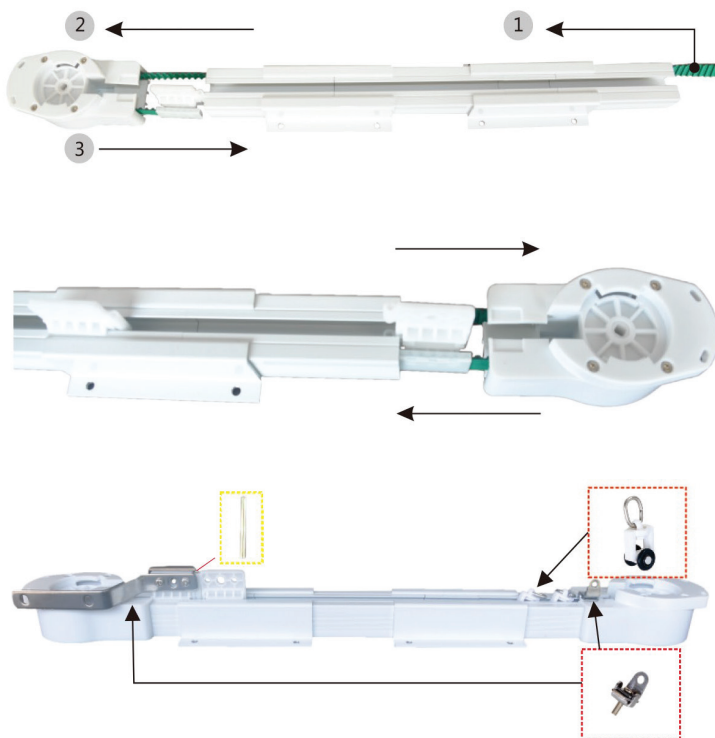

La ceinture est trop longue

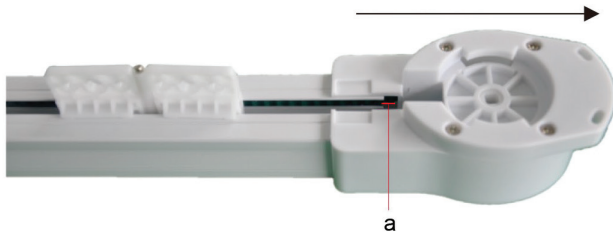

a. Écart à cet endroit, la ceinture est trop longue

La ceinture est trop courte



a. Pas d'espace, la ceinture est trop courte

Ajuster la longueur de la ceinture

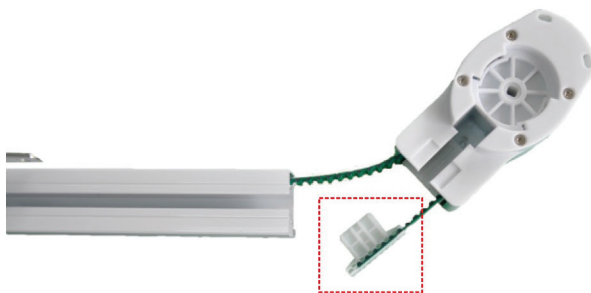

Si la ceinture est trop courte, retirez la boucle et réessayez jusqu'à ce qu'elle fonctionne correctement.

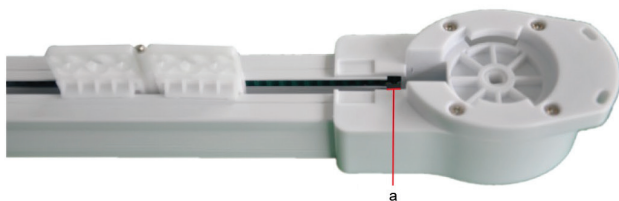

Si la courroie est trop longue, coupez-la et réessayez jusqu'à ce qu'elle fonctionne correctement..

Installation de la tringle à rideau au mur

Fixez le support au mur avec des vis autotaraudeuses M4x25mm.

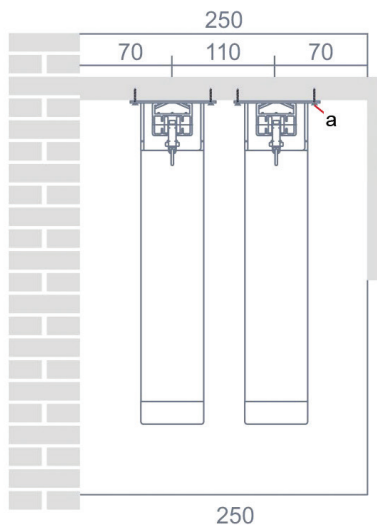
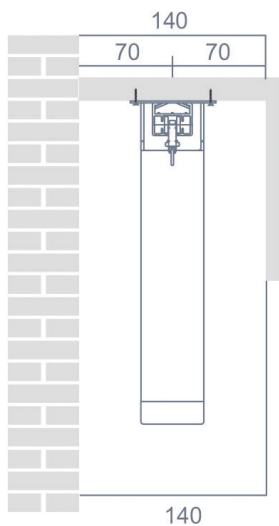
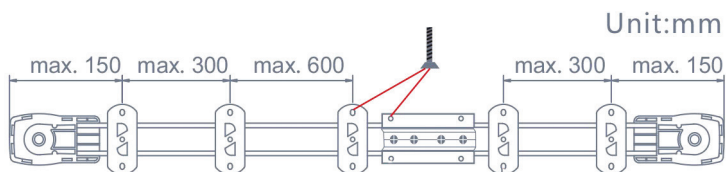

Szerelési útmutató

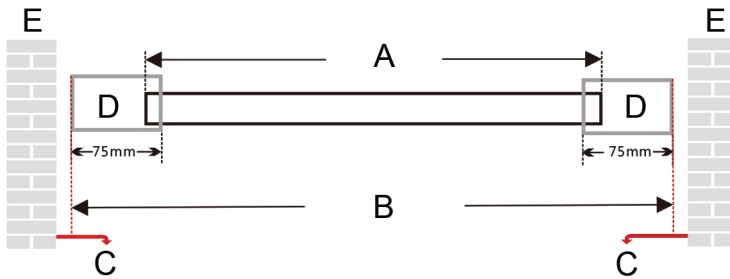

- A. Fügőnypálya
- B. Teljes hossz (faltól falig). Modelltől függően változik
- C. Legalább 5 mm távolságra a faltól
- D. Sebességváltó doboz
- E. Fal

Öv

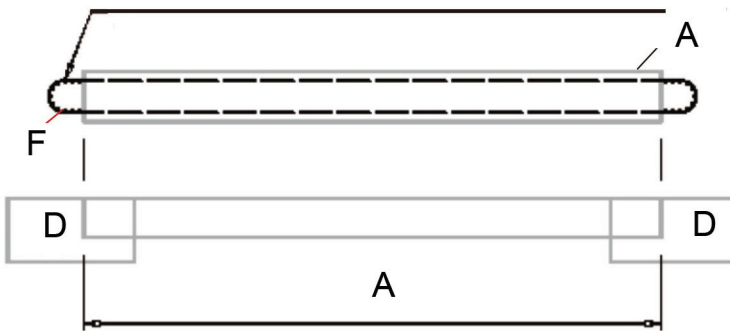

- A. Fügőnypálya
- D. Sebességváltó doboz
- F. Öv

Csatlakozz a függöny sínekhez

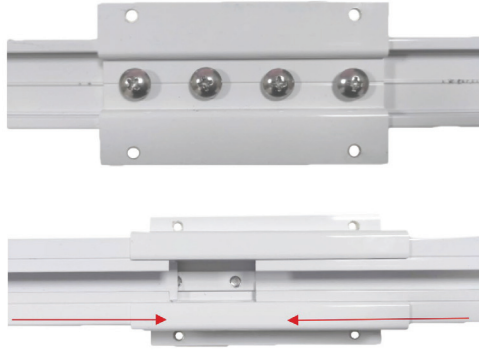

- Lazítsa meg a csavarokat, helyezze be a függöny síneket, és húzza vissza a csavarokat

Az öv összeszerelése a sebességváltó dobozban

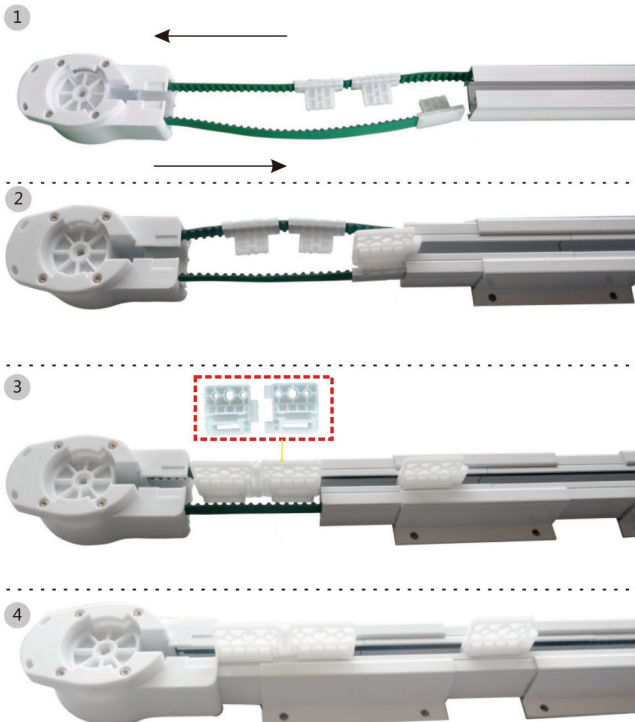

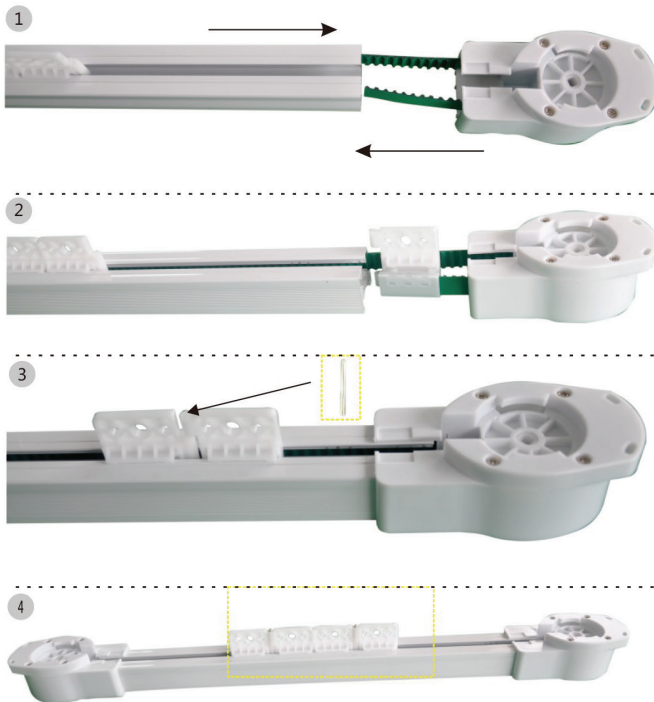

1. Vezesse át a szíjat a sebességváltó dobozán.
2. Rögzítse a függőnypályát a sebességváltó dobozban.
3. Mindkét végén járjon el a fenti képek szerint.

Szerelő gyűrűk (8 db/m) és reteszelő elem



Függönypálya összeszerelés befejezése

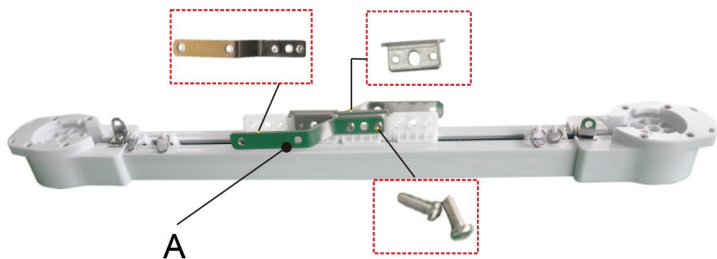

A. Kövesse a fenti képen látható összeszerelési iránynt.

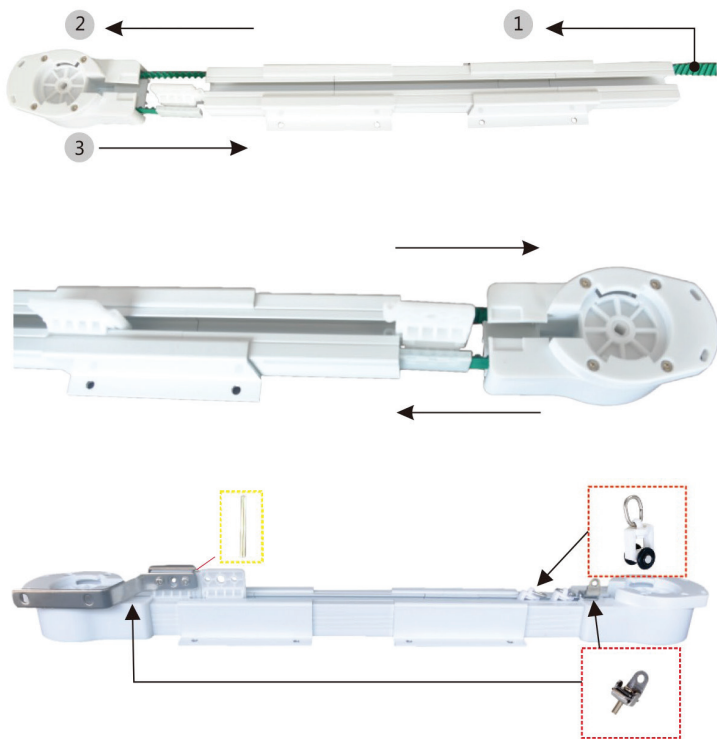

Az öv túl hosszú

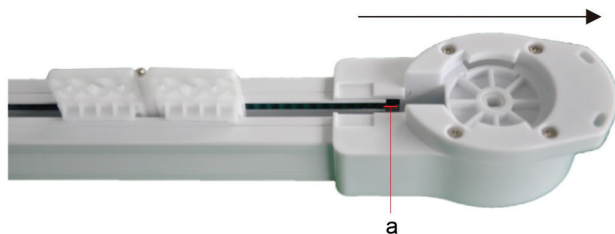

a. Rés ezen a helyen, az öv túl hosszú

Az öv túl rövid



a. Nincs rés, az öv túl rövid

Állítsa be az öv hosszát

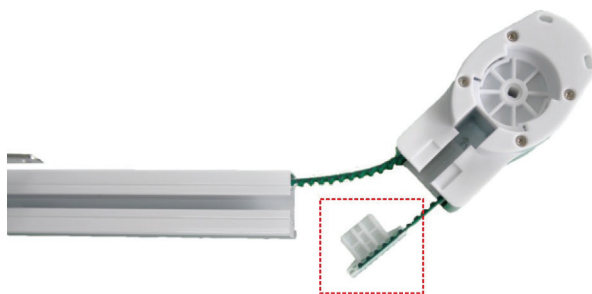

Ha az öv túl rövid, húzza ki a csatot, és próbálja újra, amíg egyenletesen fut

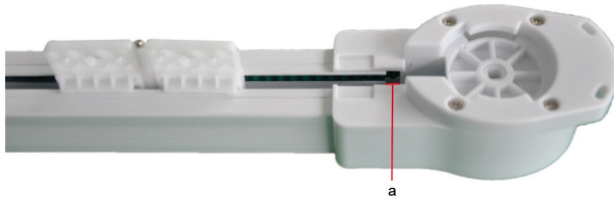

Ha a szíj túl hosszú, vágja el a szíjat, és próbálja újra, amíg egyenletesen fut.

A függönypálya felszerelése a falra

Rögzítse a tartót a falhoz M4x25 mm-es önmetsző csavarokkal.

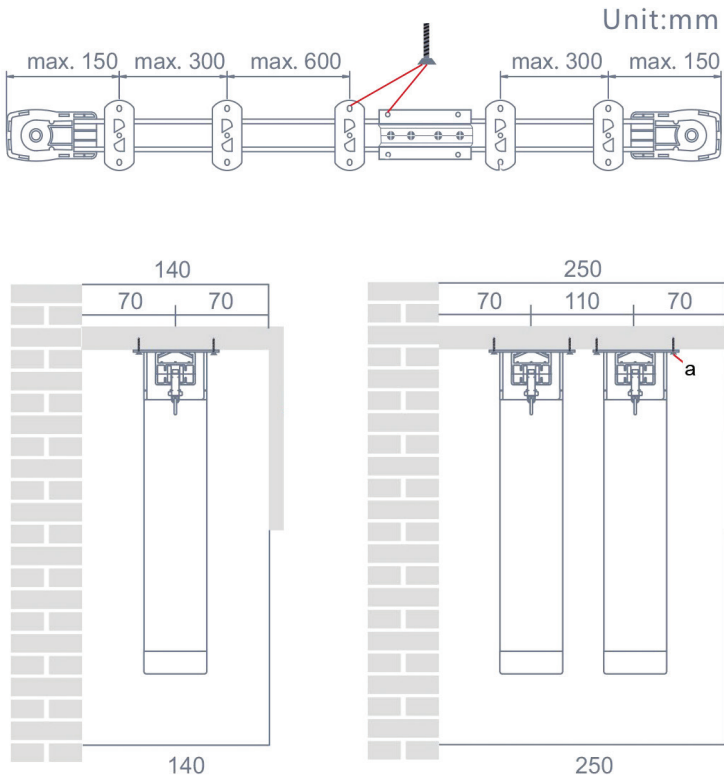

Istruzioni di montaggio

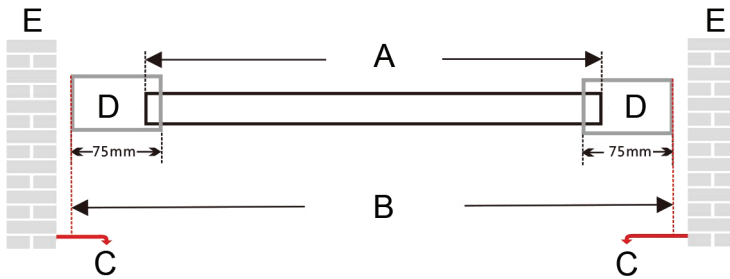

- A. Binario per tende
- B. Lunghezza totale (da parete a parete). Varia a seconda del modello
- C. Almeno 5 mm di distanza dal muro
- D. Scatola di trasmissione
- E. Muro

Cintura

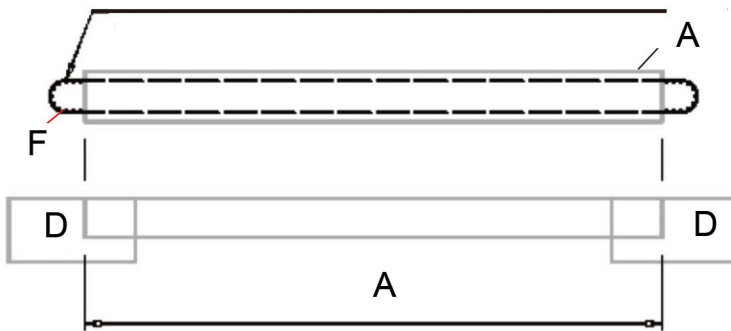

- A. Binario per tende
- D. Scatola di trasmissione
- F. Cintura

Unisciti ai binari delle tende

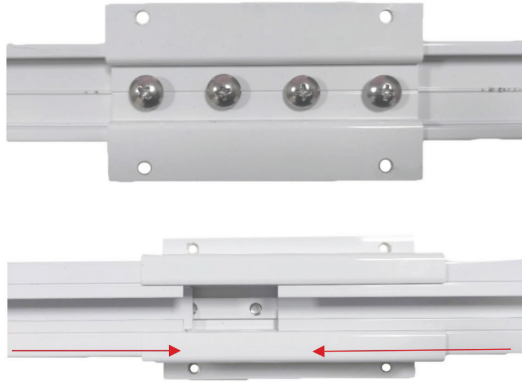

- Allentare le viti, inserire i binari della tenda e serrare nuovamente le viti

Montaggio della cinghia nella scatola di trasmissione

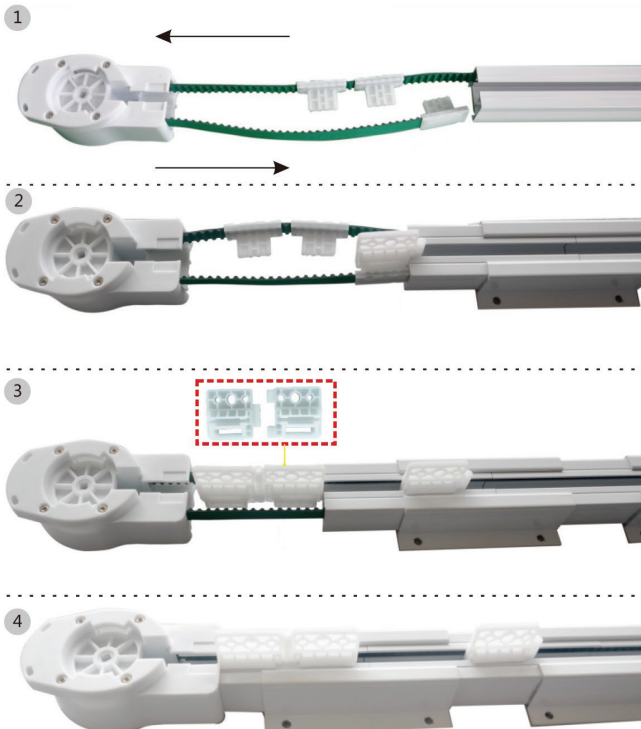

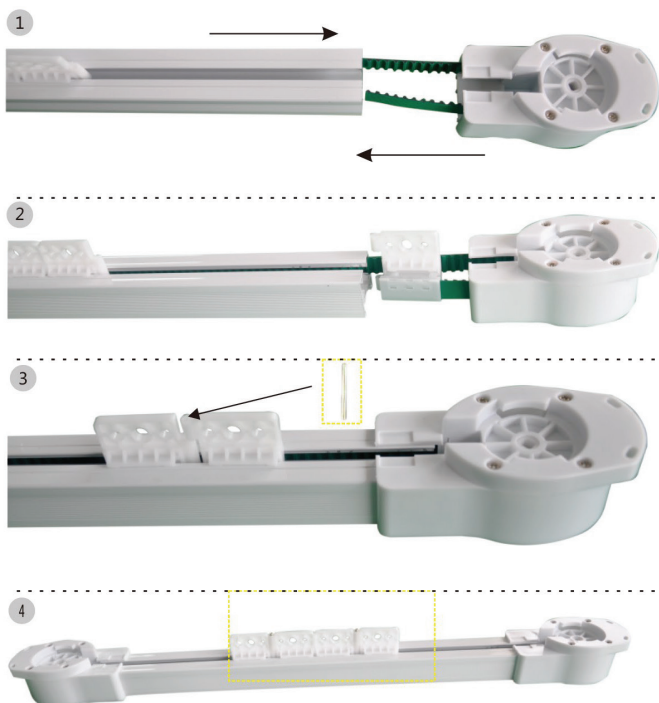

1. Passare la cinghia attraverso la scatola di trasmissione.
2. Fissare il binario della tenda nella scatola di trasmissione.
3. Procedere come nelle immagini sopra per entrambe le estremità.

Anelli di assemblaggio (8 pz/m) ed elemento di bloccaggio



Completamento del montaggio del binario per tende

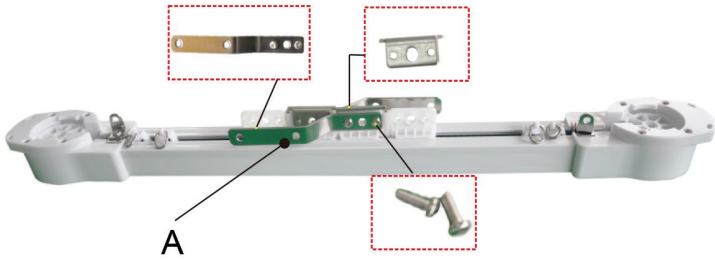

A. Seguire la direzione di montaggio come nell'immagine sopra.

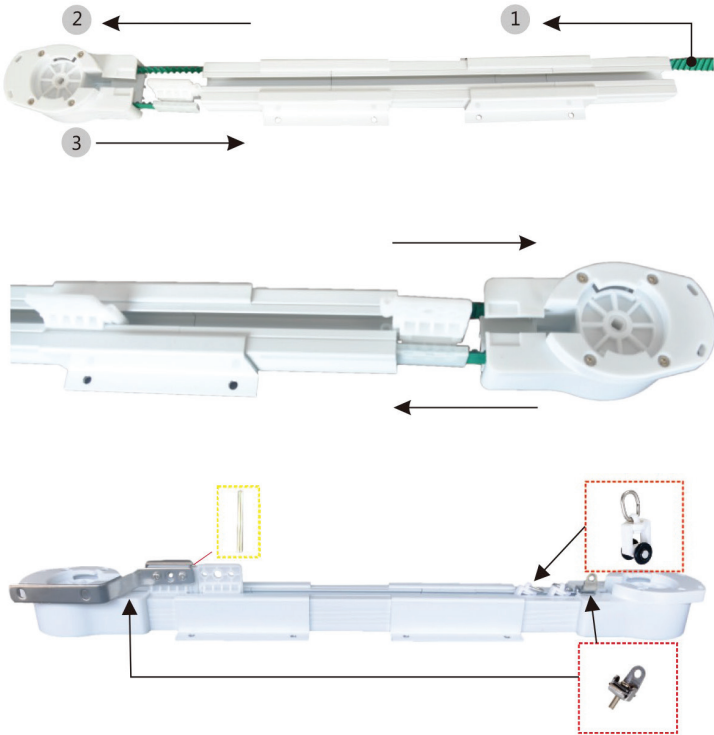

La cintura è troppo lunga

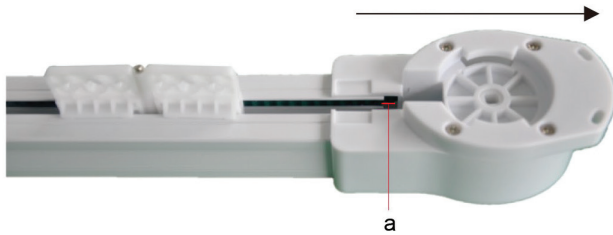

a. Spazio vuoto in questo punto, la cintura è troppo lunga

La cintura è troppo corta



a. Nessuno spazio, la cintura è troppo corta

Regolare la lunghezza della cintura

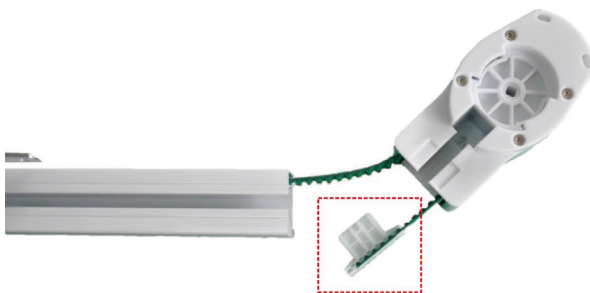

Se la cintura è troppo corta, estrarre la fibbia e riprovare finché non scorre correttamente

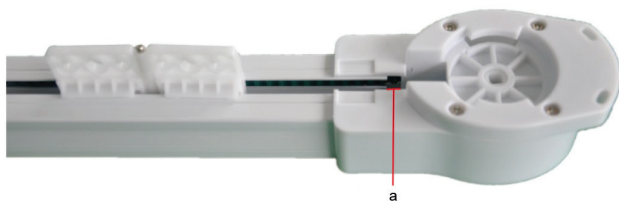

Se la cinghia è troppo lunga, tagliarla e riprovare finché non scorre correttamente.

Installazione del binario per tende sulla parete

Fissare la staffa al muro con viti autofilettanti M4x25mm.

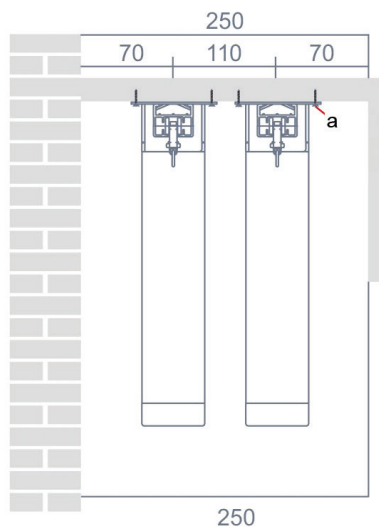
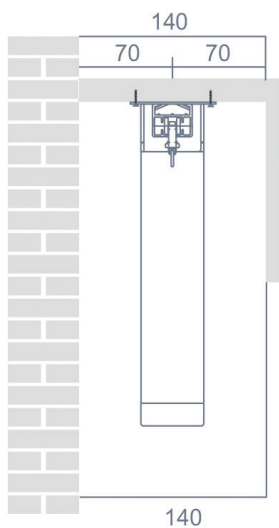
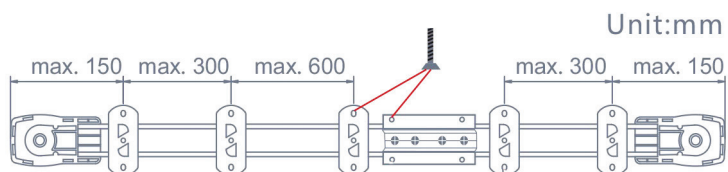

Montage-instructies

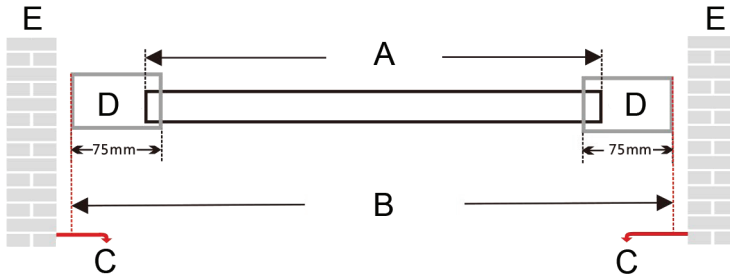

- A. Gordijnrail
- B. Totale lengte (van muur tot muur). Het varieert afhankelijk van het model
- C. Minimaal 5 mm afstand tot de muur
- D. Transmissiekast
- E. Muur

Riem

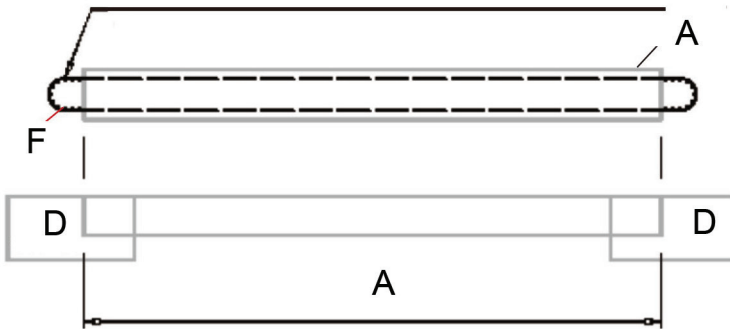

- A. Gordijnrail
- D. Transmissiekast
- F. Riem

Sluit je aan bij de gordijnrails

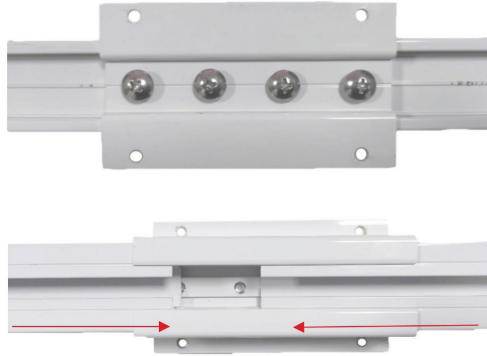

- Draai de schroeven los, plaats de gordijnrails en draai de schroeven weer vast

Montage van de riem in de transmissiekast

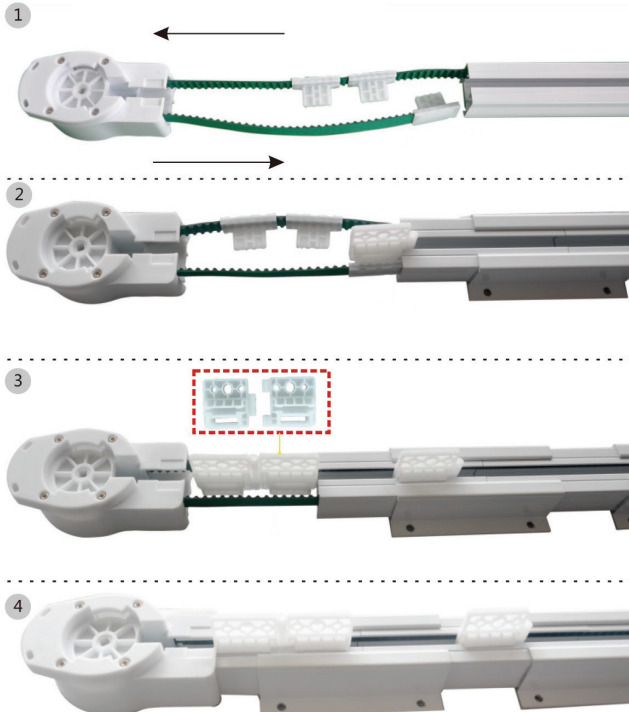

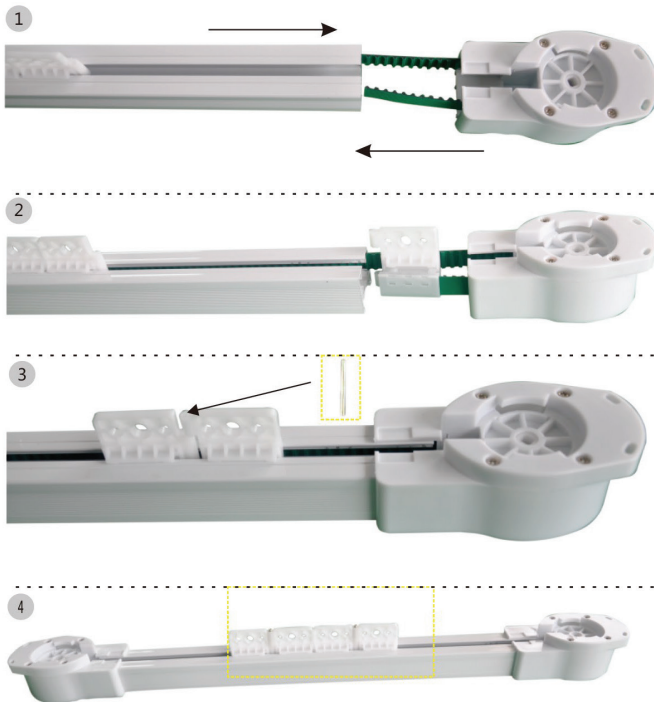

1. Leid de riem door de transmissiekast.
2. Bevestig de gordijnrail in de transmissiekast.
3. Ga voor beide uiteinden te werk zoals in de bovenstaande afbeeldingen.

Montageringen (8 stuks/m) en borgelement



Voltooiing van de montage van de gordijnrail

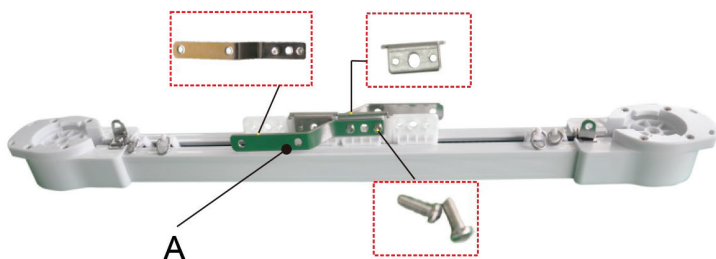

A. Volg de montagerichting zoals in de afbeelding hierboven.

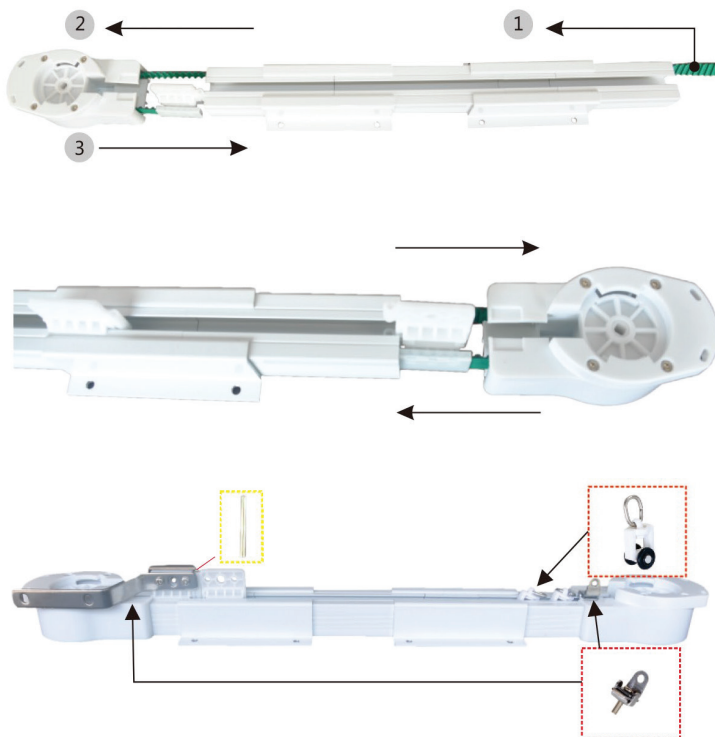

De riem is te lang

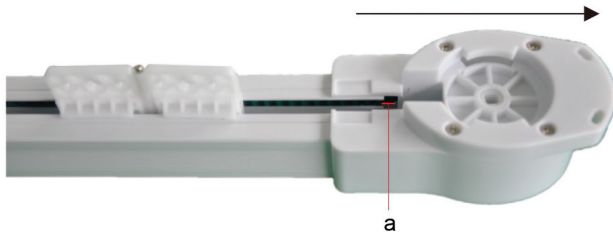

a. Gat op deze plek, de riem is te lang

De riem is te kort



a. Geen opening, de riem is te kort

Pas de riemlengte aan

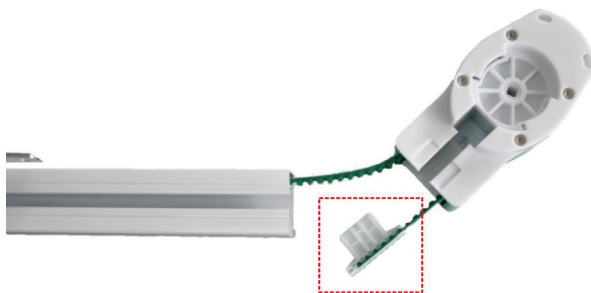

Als de riem te kort is, trek dan de gesp eruit en probeer het opnieuw totdat deze soepel loopt

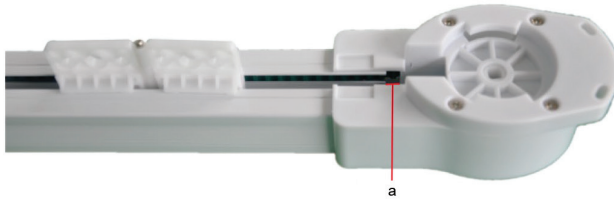

Als de riem te lang is, knipt u de riem door en probeert u het opnieuw totdat deze soepel loopt.

Het installeren van de gordijnrail aan de muur

Bevestig de beugel aan de muur met M4x25mm zelftappende schroeven.

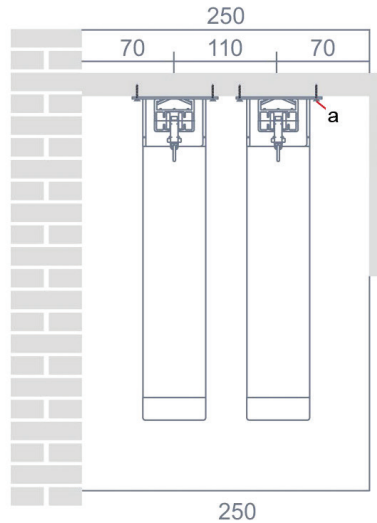
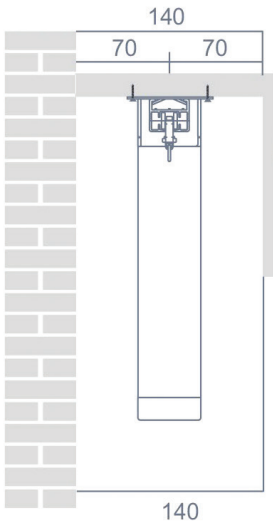
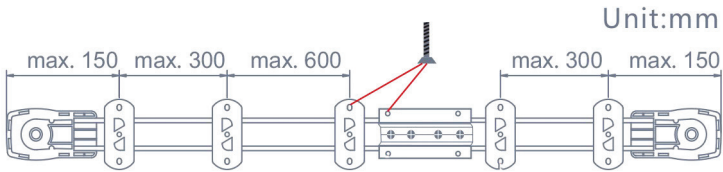

Instrukcje składania

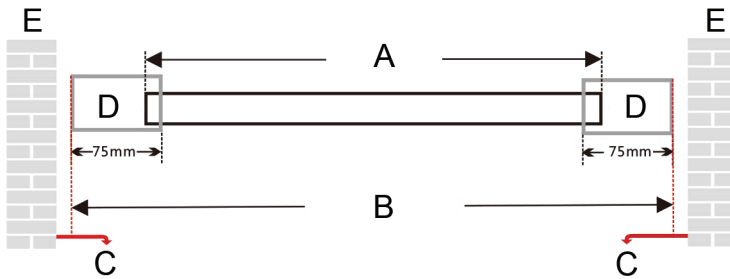

- A. Tor kurtynowy
- B. Długość całkowita (od ściany do ściany). Różni się w zależności od modelu
- C. Odległość od ściany co najmniej 5 mm
- D. Skrzynia transmisyjna
- E. Wall

Pasek

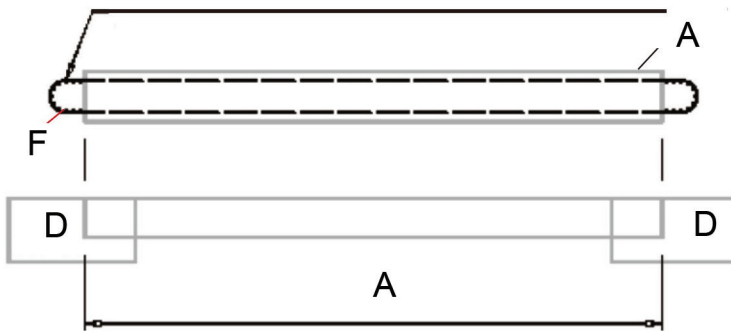

- A. Tor kurtynowy
- D. Skrzynia transmisyjna
- F. Pasek

Dołącz do torów kurtynowych

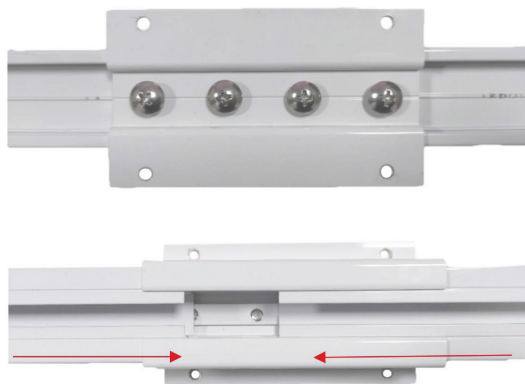

- Poluzuj śruby, włóż prowadnice zasłon i ponownie dokręć śruby

Montaż paska w skrzyni biegów

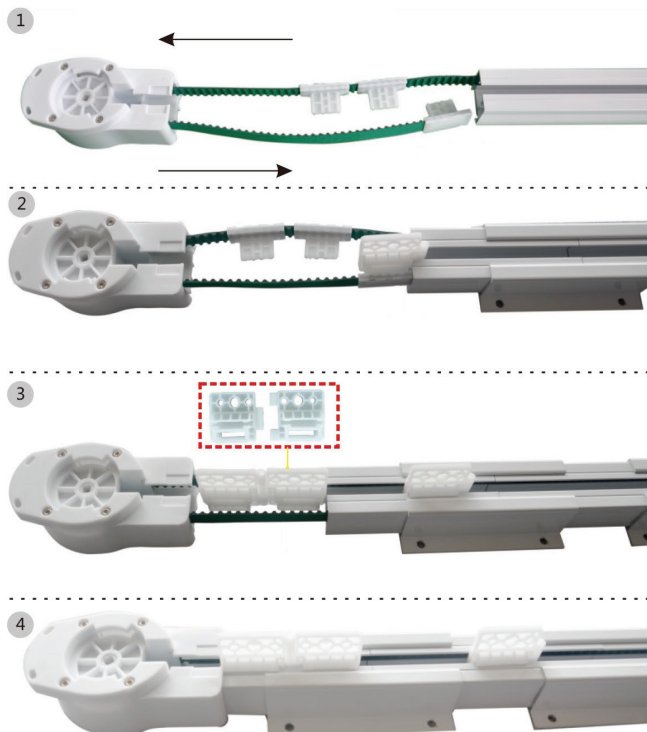

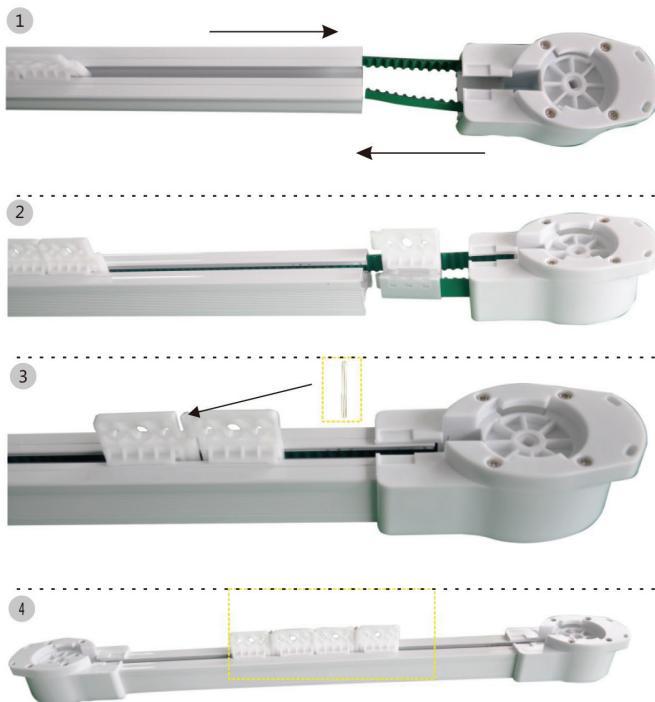

1. Przetłóż pasek przez skrzynię biegów.
2. Zamocuj prowadnicę kurtyny w skrzynce transmisyjnej.
3. Postępuj jak na powyższych ilustracjach dla obu końców.

Pierścienie montażowe (8 szt./m) i element blokujący



Zakończenie montażu prowadnicy kurtyny

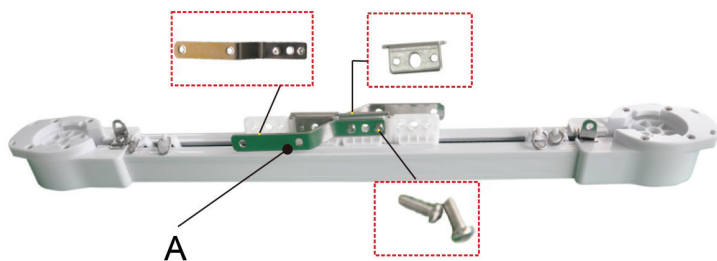

A. Postępuj zgodnie z kierunkiem montażu jak na powyższym obrazku.

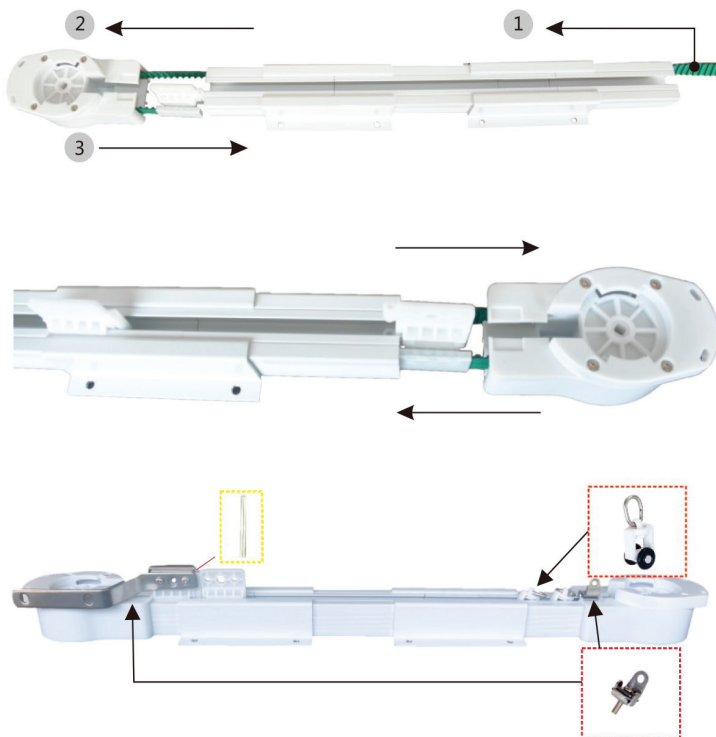

Pasek jest za długi

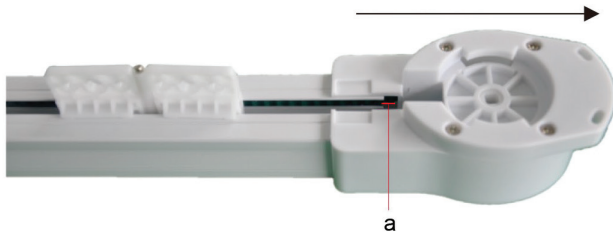

a. Szczelina w tym miejscu, pasek jest za długi

Pasek jest za krótki



a. Brak luzu, pasek jest za krótki

Dostosuj długość paska

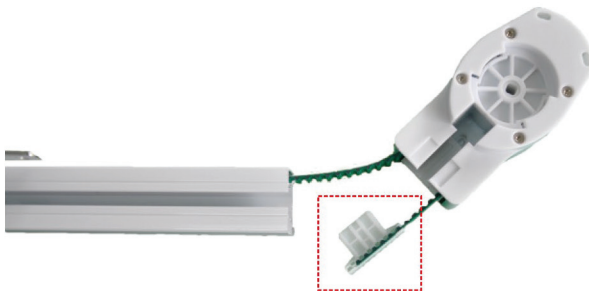

Jeśli pasek jest za krótki, wyciągnij klamrę i spróbuj ponownie, aż będzie chodzić gładko

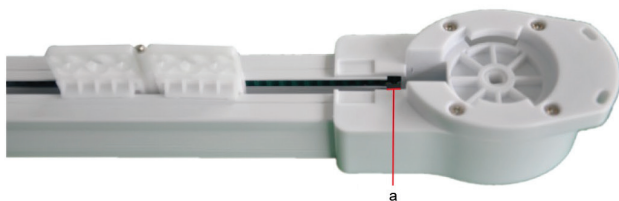

Jeśli pasek jest za długi, przetnij go i spróbuj ponownie, aż będzie przebiegał gładko.

Montaż prowadnicy kurtyny na ścianie

Przymocuj wspornik do ściany za pomocą wkrętów samogwintujących M4x25mm.

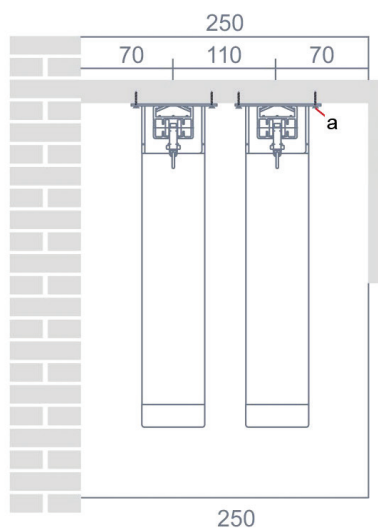
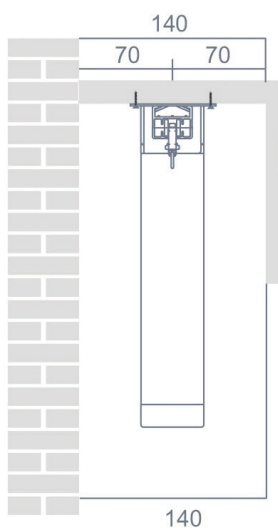
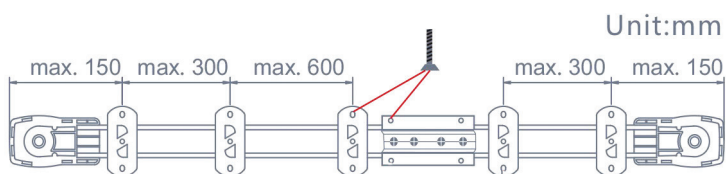

Instructiuni de asamblare

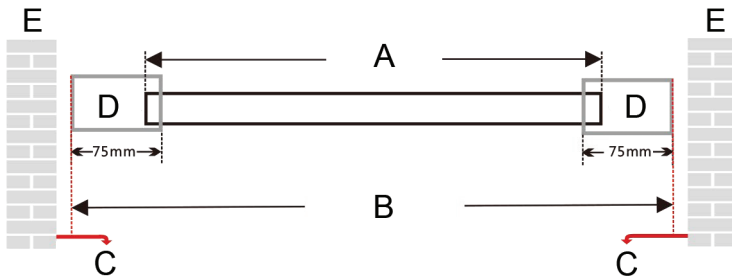

- A. Sina draperie
- B. Lungime totala (din perete in perete). Variaza in functie de model.
- C. Cel putin 5 mm distanta fata de perete
- D. Cutia de transmisie
- E. Perete

Curea rulare

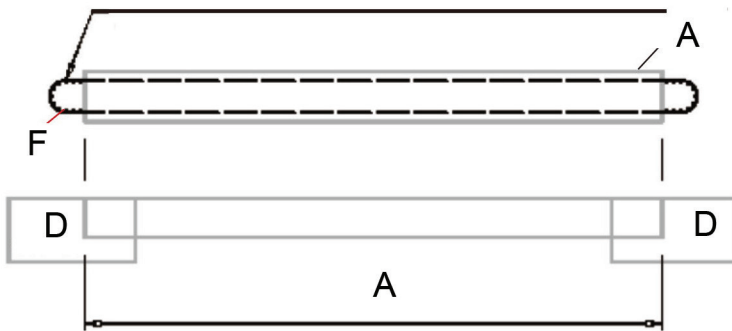

- A. Sina draperie
- D. Cutia de transmisie
- F. Curea rulare

Imbinare sine

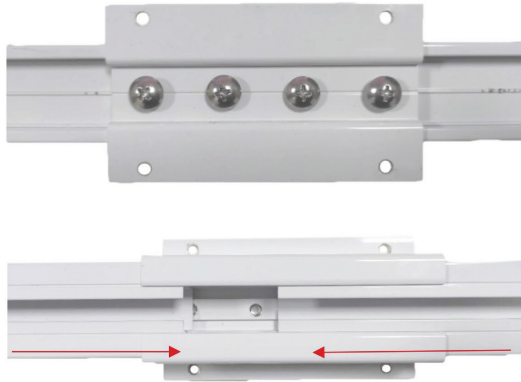

- Desfaceti suruburile, bagati sinele si strangeti suruburile la loc

Asamblare curea in cutia de transmisie

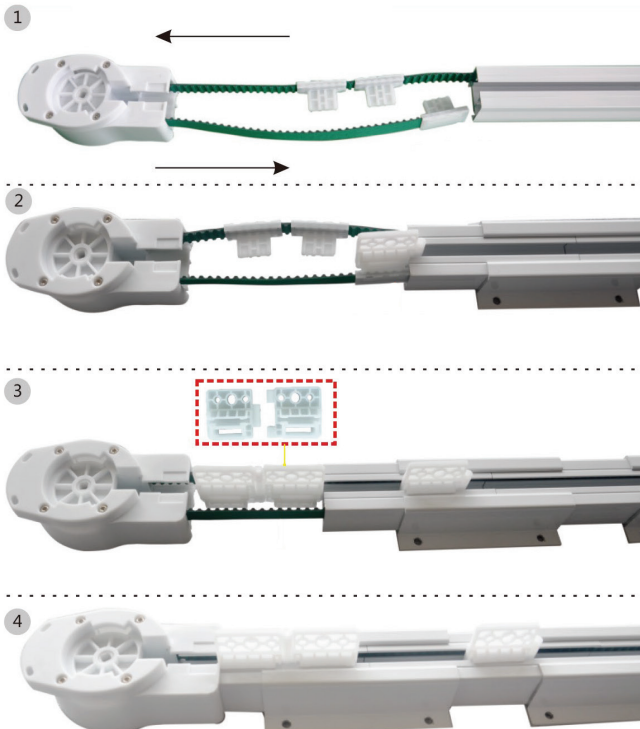

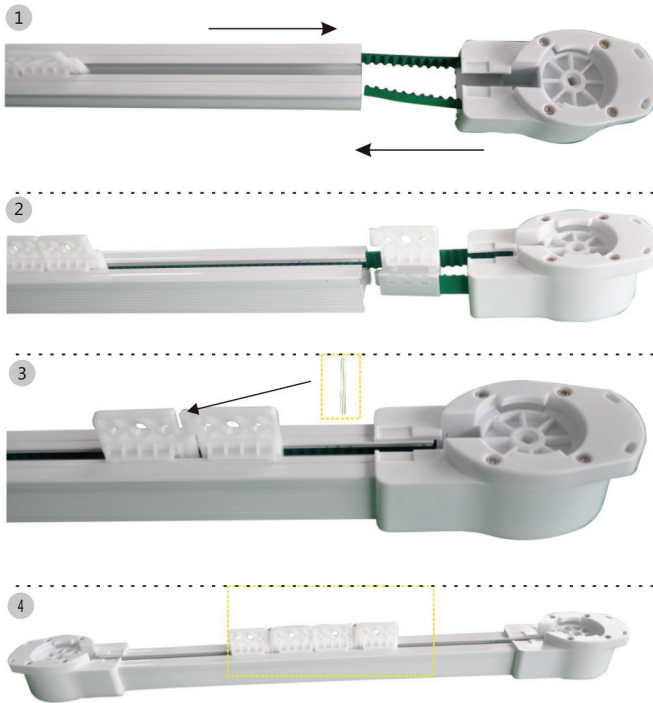

1. Treceti cureaua prin cutia de transmisie.
2. Fixati sina in cutia de transmisie.
3. Procedati ca in imaginile de mai sus pentru ambele capete.

Asamblare inele (8 buc/m) si element de blocare



Finalizare asamblare sina

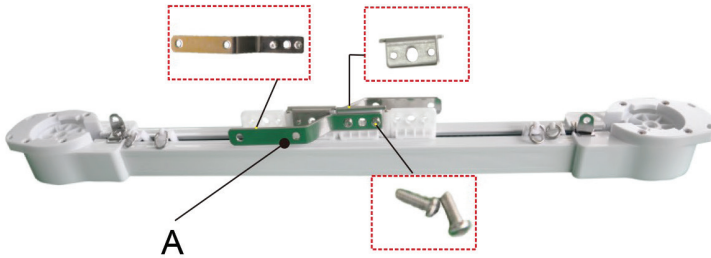

A

A. Respectati directia de montaj ca in imaginea de mai sus.

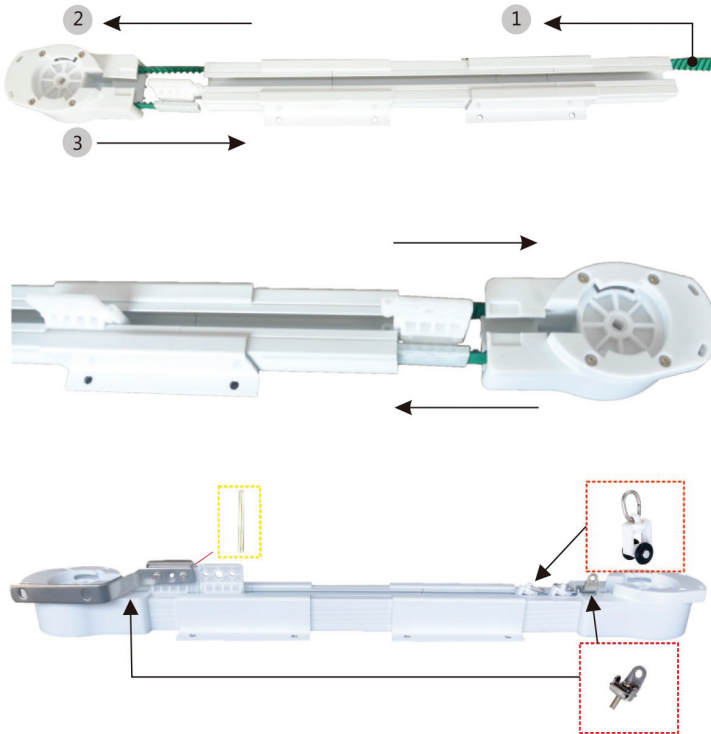

Cureaua este prea lunga

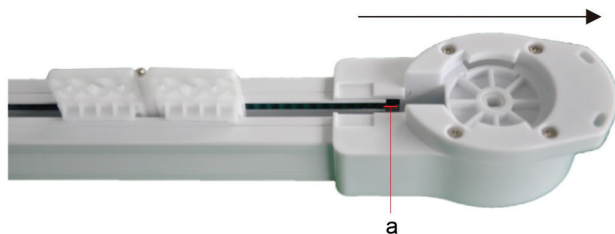

- a. Spatiu in acest loc, cureaua este prea lunga

Cureaua este prea scurta



- a. Fara spatiu, cureaua este prea scurta

Reglare lungime curea

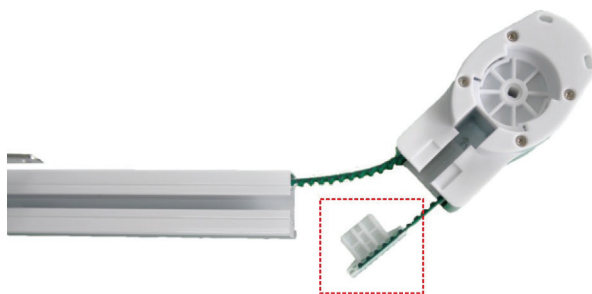

Daca este prea scurta cureaua, scoateti catarama in afara.

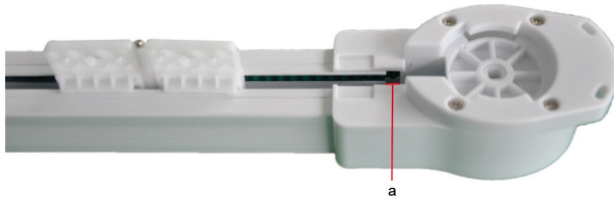

Daca este prea lunga cureaua, taiati cureaua.

Instalare sina pe perete

Fixati suportul de perete cu suruburi autofiletante M4x25mm.

